



KNOTS FOR CAMP - Most useful knots. Whipping. Knot-tying racks. Knots and tent pitching contests.

Knots

Patrol Teams

TAUT-LINE HITCH RACE

Equipment: Rope ring around tree. For each participant rope of sufficient length to reach around peg for tying taut-line hitch. Pegs hammered around tree in circle.

Action: All ropes are lying with ends slack on ground. Then Scouts line up next to tent pegs. On word "Go," each Scout grasps rope end, ties taut-line hitch. When all Scouts of patrol have finished, patrol gives yell. First to yell, with all hitches correct, wins.

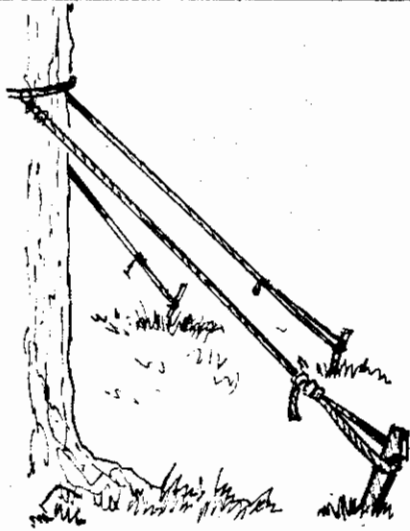

Knots

Patrol Teams

CLOVE HITCH RACE

Equipment: Set up rack of three spars on six uprights. Tie rope of sufficient length to spar in middle with clove hitches. Drape ends over other spars. One rope for each participant.

Action: Scouts line up at ropes. On word "Go" each Scout grasps rope end, ties clove hitch around spar. When all Scouts of patrol have finished, patrol gives yell. First to yell, with all hitches correct, wins.

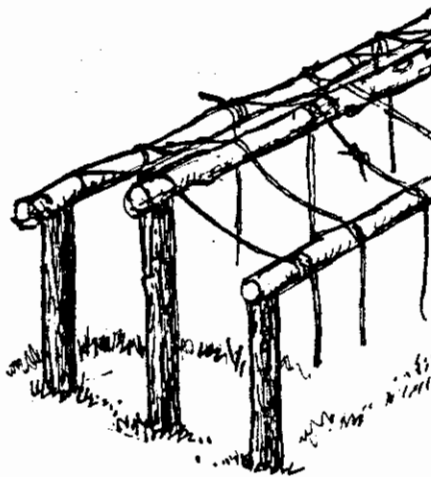

KNOTS for camp Whipping rope end before tying to prevent unraveling

Make a loop of twine and place at end of rope.

Wrap twine tightly around rope starting 1/4 inch from rope end.

When whipping is as wide as rope is thick, pull out ends hard. Trim off twine close to whipping.

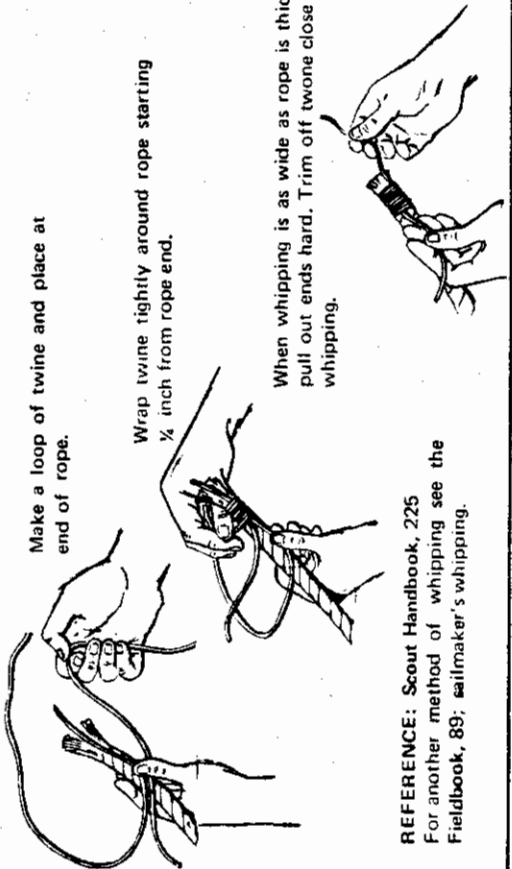

REFERENCE: Scout Handbook, 225
For another method of whipping see the Fieldbook, 89; sailmaker's whipping.

Informal

Half-Patrol Teams

TENT-PITCHING CONTEST

Equipment: For each half-patrol team, one two-boy tent, poles, pegs, guy lines, properly packed; one or two axes.

Action: Teams line up opposite to the equipment. At the signal "Go" each team erects its tent. When completed, guy lines must be taut with knots correctly tied, tent sides smooth, pegs properly placed, tent door closed.

Scoring: First patrol gets 100 points, second 80 points, and third 60 points. Deduct 5 points for every incorrectly tied knot or any other fault.

TENT-STRIKING CONTEST

Action: Tent is already pitched. Idea is to take down tent, fold it, tie it up neatly. Pegs are to be pulled out of the ground and placed beside folded tent. Judge for correctness and teamwork.

KNOTS for camp

Knots for joining and making loop

SQUARE KNOT

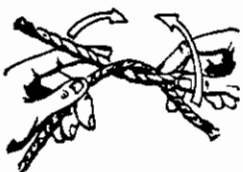

SHEET BEND



BOWLINE



KNOTS for camp

Knots for attaching rope

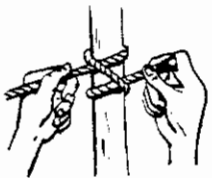

CLOVE HITCH



TWO HALF HITCHES

TAUT LINE HITCH



Knots



GAMES—OBSERVATION, DEDUCTION I - Memory training through observation and deduction. Troop and patrol activities.

Patrol Teams

Observation-Memory Informal

CHECKERBOARD KIM'S GAME

Equipment: Square off a large piece of cardboard into 16 squares. Number them, place item on each square: Key, pocketknife, nail, acorn, and so on.

Action: Patrol walks silently around each item. All items are then removed and put in a pile. Patrol members walk around table again, each boy replacing item to correct square, without talking.

Scoring: Patrol with most items correctly replaced wins.

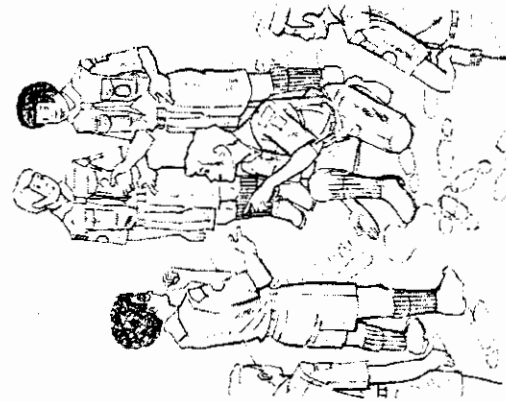

Patrol Teams

Observance-Memory Informal

KNOT TRAIL (Knot Kim's Game)

Equipment: Tie several pieces of rope of varying thicknesses together, using several different knots (square, sheetbend, bowline, two half hitches, taut-line hitch). Tie one end of rope to one tree with clove, the other end to another tree with taut-line hitch.

Action: Patrol is told to walk along rope from tree to tree and back again, silently, to observe and remember (approximately 2 minutes). Patrol then goes into huddle to come up with list of knots seen (including knots around trees) in right order.

Scoring: Patrol with best list wins. Trick question for extra points: How many ropes used?



Patrol Teams Informal Observation-Deduction

WHAT HAPPENED?

Equipment: Prepare a tracking pit by digging up and raking an area about 10 feet by 15 feet. Then stage a simple tracking project to be observed and deduced:

The Good Turn - Blind man (with cane) walks into tracking pit. A Scout joins him, takes his arm, walks him out.

Table Carry - Four men carry heavy patrol table into tracking pit. They stop, put down table, rest on benches, stand up, pick up table, carry it off.

Tired Scout - Scout comes stumbling in, gives up, sits down. Other Scout enters, picks him up, carries him off. Patrols study tracks for 5 minutes, go into huddle, present their deduction orally. Game leader does not indicate them right or wrong, but rakes pit, calls in original track makers to repeat action.

Patrol Teams

Observation-Memory Informal

SLOPPY CAMP

Equipment: Set up tent and simple fireplace with many things wrong - ax on ground, glass jar in fireplace, poorly set tent pegs, wrong knots on guy lines, etc. But also with such personal items as these: two blankets and one sleeping bag in tent, two neckerchiefs of different colors draped over guy line, two Scout shirts with different troop identification and name tags, etc.

Action: Patrol studies camp for 5 minutes without talking. Scouts are permitted to touch what they see, but must replace exactly as found. Patrol then gets into huddle to come up with list of wrong things.

Scoring: Patrol with best list wins.

Extra: When patrol turns in list, it gets a card with questions such as these: "How many boys camped in the sloppy camp?" "To what troops and patrols did they belong?" "What were their names?" (according to items used).



Patrol Teams Informal Observation-Memory

INVISIBLE KIM'S GAME

Equipment: Two empty packs (and lots of imagination)

Action: Patrol members listen, in silence, while game leader opens "full" packs, takes out nonexistent (therefore "invisible") items, shows in pantomime how item is used, then puts it in "empty" pack. Samples: rope (show how knot is tied), wrist watch (winds it, shakes it), flashlight (can't get it to work), telephone, handkerchief, lollypop, etc.

Scoring: Patrol coming up with most correct list wins.

FLYING SAUCER KIM'S GAME

Equipment: Pack with 15-20 items, one empty pack.

Action: Game leader takes item out of pack, throws it to assistant who drops it in his pack. Patrol is to identify flying items, then make list of them.



GAMES—OBSERVATION, DEDUCTION II—Memory training through observation and deduction. Troop or patrol activities.

Observation- Patrol Teams Informal Memory

WHAT DO I FEEL?

Equipment: Fifteen to 20 articles (marble, coin, pocketknife, hammer), paper and pencil for each patrol, neckerchiefs for blindfolds.

Action: Have patrols form circle. Boys face in, put on blindfolds, hand articles, one by one, to the first Scout in line. He feels article and passes it on to the next in line. Second Scout feels article and passes it on. This is continued until all items have made a complete circle. Remove blindfolds and have patrols write down the items in the order in which they were passed.

Scoring: Give 10 points for each correct answer. Patrol with highest score wins.

NOTE: Instead of circle, have patrol in line, standing or seated on log, without blindfolds, pass items behind their backs. Game leader feeds items to first Scout, picks them up from last Scout.



Observation- Patrol Teams Informal Memory

WHAT DO I SMELL?

Equipment: Paper bags with different-smelling article in each; paper and pencil for each patrol.

Action: Prepare a number of paper bags and put into each a different article (licorice, onion half, coffee, orange peels, cinnamon). Place these bags about 2 feet apart on a table or bench. On signal, each Scout (blindfolded) walks down the line and sniffs at each bag for five seconds. When all members of a patrol have passed by, they go into a huddle and write down the names of the different articles smelled.

Scoring: Give 10 points for each correct answer.

NOTE: Instead of bags, have smells in 35mm film containers (top punctured; liquid on cotton) or in Styrofoam cups (covered with foil, taped on, punched with fork holes). Scouts at table, passing and smelling items.



Observation- Patrol Teams Informal Memory

KIM'S GAME

Equipment: Several items (20 or 30), a large cloth or neckerchief, and paper and pencil for each patrol.

Action: Spread the items on a table and cover with a cloth or neckerchief. Gather the patrols around. Lift the cloth for one minute and allow patrols to observe. Cover the items after the minute is up and have patrol members list them on a slip of paper. Scoring: Allow 1 point for each correct item listed. Patrol with most correct items is the winner.

Variation—UP-AND-DOWN KIM'S GAME: Tie items along length of rope. Throw one end of rope over tree limb. Items are out of sight (in pack or ice cooler). Game leader pulls rope, revealing items, then lowers them again. Patrol writes list, in correct order.



If printed on heavy stock, cut along solid lines to make file cards. If printed on paper, cut apart, paste on file cards to create your SCOUTCRAFT FILE.

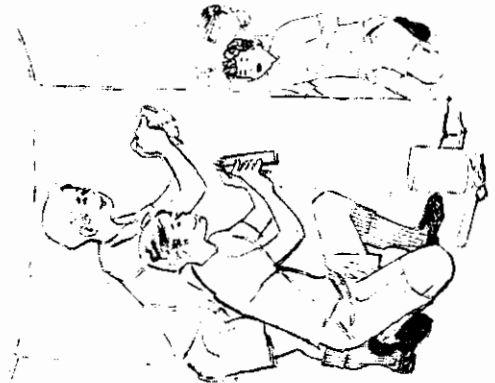

Observation- Patrol Teams Informal Memory

HAUNTED HOUSE

Equipment: Blanket hung up as a curtain. Miscellaneous props for making sounds.

Action: Patrols are seated in front of curtain. Behind curtain are two boys who produce various sounds for the Scouts to recognize and remember, such as: Turn pages of a book, unwrap cellophane wrapper, break stick, strike match, hammer nail and so on. After demonstration, patrols retire to their corners to make a list of noises heard.

Scoring: Three points for each sound listed. Variation—OVERHEARD PLOT: Instead of making noises, the two Scouts behind the curtain engage in a dialogue planning, for example, the burying of a dead skunk or the killing of a turkey—speaking in either case of "him" instead of calling the animal or fowl by name. Patrols go to their corners and write reports. Results may surprise you.



Observation- Patrol Teams Informal Memory

THE LEAKING PACKSACK

Equipment: Various pieces of camping equipment OR items which would normally be included in a "lost kit." Paper and pencils.

Action: Game leader arranges various articles not too conspicuously along one side of a path. They may include flashlight, toothbrush, soap, toothpaste, stocking, spoon, comb, etc. OR compass, map, piece of fishing line, matchbox, etc. The whole troop passes slowly along the road in single file. No one is permitted to walk back when he has passed a certain article. Afterwards patrols go into huddles and prepare list of articles seen, in right order.

Scoring: Patrol with most complete list, wins.

Variation: Patrol turns in its list of items noticed arranged in the order in which it considers the various pieces of equipment of importance to a camper, or to a lost person.



GAMES AND CONTESTS—WOODS TOOLS—Patrol and half-patrol teams competing in using ax, knife, bowsaw.

Axmanship Patrol Teams Parallel File
CHOPPERS' RELAY (Splitting)

Equipment: For each patrol, one hand ax, two boards, 6" wide, 9" long, 1" thick, one chopping block.

Action: Patrol in relay formation. Scout No. 1 runs up, picks up one board and ax, splits off strip of board, holding board flat and using contact method. Nos. 2, 3, and 4 follow, making five pieces of even size (about 1" x 1") of first board. Then Nos. 5, 6, 7, and 8 do the same to second board. **Result:** 10 pieces made with eight cuts. Patrol yell when finished.

Variation—CHOPPING RELAY (Splitting and cutting)

Equipment: Same as for Choppers' Relay. **Action:** First part is the same as the Choppers' Relay. The second part is to cut each piece in half, using the contact method.

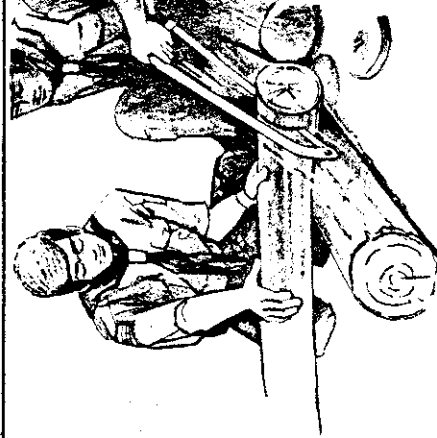

Variation—TWO-MAN CROSS-CUT RELAY. Scouts, in two-man teams, cut 4-inch thick disks from log 12 inches in diameter. First patrol with 4 disks wins.

Axmanship Patrol Teams Parallel File
SPLIT THE MATCH

Equipment: A Scout ax and a chopping block for each patrol and a stick match for each Scout.

Action: Patrols are in relay formation with a chopping block and ax in front of each. On signal, first Scout in each patrol walks up to the chopping block, places his match (head up) in the chopping block, and is given three strokes with the ax to split the match. When he has had his three strokes (or less if he splits the match with less strokes), he walks back to his patrol and touches off the next in line who repeats the same procedure. This continues until all patrol members have tried it.

Scoring: The patrol that splits the most matches wins. This is not a race.

Warning: Exercise safety precautions in the handling of axes and matches.



Log Sawing Patrol Teams Parallel File
BOW-SAW RELAY

Equipment: For each patrol, one bow saw, one log about 6 feet long with a 4-inch butt, one short log or block for support.

Action: Patrols line up in relay formation facing the logs at a distance of 20 feet. Bow saw is placed alongside the log. On signal two Scouts from each patrol run up to log. One Scout supports log while second saws off a disk about 2 inches thick. As soon as disk drops to ground, Scouts change positions and another disk is sawed off. When the second disk hits the ground, both Scouts race back to starting line and touch off next two Scouts who repeat the process. This continues until all Scouts have had a chance to saw and until a total of eight disks have been sawed off and all members of the patrol have returned to the starting line. **Scoring:** The first patrol to finish is the winner.

Axmanship Patrol Teams Parallel File
TENT PEG MAKING RELAY

Equipment: Eight pieces of wood, 9 inches long, ax, and chopping block.

Action: From relay formation, first Scout runs up to chopping block at opposite wall of room (or 50 feet away, if in the out-of-doors), takes ax and makes regular tent peg, pointed at one end and with notch at the other. He runs back to touch off No. 2. Continue until eight pegs have been made.

Scoring: Patrol finishing first, with pegs neat, usable and uniform, wins.

Variation—TENT PEG DRIVING RELAY. Outdoors, each patrol lines up in relay formation, with eight tent pegs and ax lying on ground fifty feet in front of it.

Action: First Scout runs up drives all eight pegs into ground, pulls them all out again and races back to touch off next runner.

Scoring: First patrol to finish eight runs, wins.

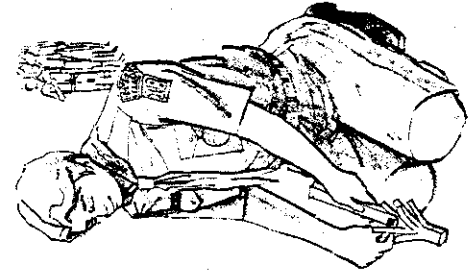

Knife Patrol Teams Parallel File
FUZZ STICK RELAY

Equipment: For each patrol, one sharp knife and one stick of dry, soft wood about 1/2" x 1" x 9".

Action: Each patrol lines up in relay formation opposite equipment. On signal, Scout No. 1 runs up and cuts one sliver on stick, lays knife down and runs back to touch off No. 2 Scout, who runs up—and so on. Slivers should be at least 3" long. 20 slivers, all attached, complete the fuzz stick. **Scoring:** First patrol to finish scores 10 points. Best fuzz stick scores 30 points, the next best 15 points.

Variation 1—Instead of having each player cut one sliver, players cut three or four slivers.

Variation 2—To vary scoring, take off 5 points for each sliver that is cut off the fuzz stick and see how many patrols end up in the "red."

If printed on heavy stock, cut along solid lines to make file cards. If printed on paper, cut apart, paste on file cards to create your SCOUTCRAFTFILE.



GAMES AND CONTESTS - FIRE BUILDING - Contests among patrol representatives. Filecards on fires and woods.

FIRE MAKING I

References: For further material on tinders, see *Fieldbook*, page 117. The method of making fire by flint-and-steel is described in the *Fieldbook*, pages 310-311. Fire by friction is described on page 312.

1. FIRE STARTERS



MATCHES
KITCHEN SIZI ARE BEST. WATERPROOF WITH PARAFFIN, NAIL POLISH, OR SHELLAC. CUT 50-50 WITH ALCOHOL.
FLINT AND STEEL
ANY QUARTZ CONTAINING STONE IS GOOD. FOR STEEL, USE BACK OF KNIFE BLADE OR FILE WITH BURR GRIND OFF.

2. TINDER



GRASS
FINE, DRY - UP OFF THE GROUND.
WEEDTOPS
GOLDENROD, ASTER, ETC.
FINE TWIGS
"SQUAW WOOD" FROM STANDING TREES
BARK
CEDAR OR BIRCH OR PALMATIO - PICKED FROM DEAD STANDING TREES WITH YOUR FINGERS AND NAILS
BIRDS' NESTS FROM LAIR SEASON
MOSS NESTS

FIRE MAKING II

Kindling and fuel - their collection and preparation - are described in *Fieldbook*, pages 117 and 72-73. For a listing of best firewoods, see *Golden Book of Camping*, page 46.

3. KINDLING



"SQUAW WOOD" THE FINE TWIGS AND BRANCHES THAT A SQUAW CAN GET FROM A STANDING TREE WITHOUT USING ANY TOOL OTHER THAN HER HANDS

TWIGS
DEAD, DRY "SQUAW WOOD" FROM STANDING TREES.
WEED STEMS
MEDIUM AND HEAVY STEMS
SPLIT WOOD
ALWAYS GOOD AS LONG AS IT IS:
1) DRY
2) SPLIT FINE ENOUGH
3) MORE THAN YOU THINK YOU NEED

4. FUEL



NEVER USE GASOLINE OR ANY LIQUID FUEL FOR FIRE STARTING.

WOOD
ANY SIZE, BETTER SPLIT IT IF YOUR LOG IS MORE THAN 3 INCHES IN DIAMETER.
CHARCOAL
IN NATURAL "STICKS" OR PRESSED BRIOULETS.
COAL
SOFT OR HARD

FIRE MAKING III

See *Fieldbook*, pages 118-119, for fire lays for quick fire making lean-to, fire-stick, cross-ditch. Traditional campfire: page 120.

HUNTERS' FIRE
USE LOGS FOR SIDES... LINE UP WITH WIND
ROCK FIRE
ONE OF THE BEST TYPES OF FIRES - ESPECIALLY FOR SEMI-FIXED CAMP

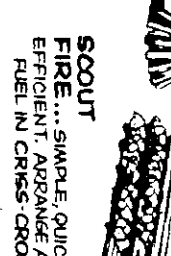
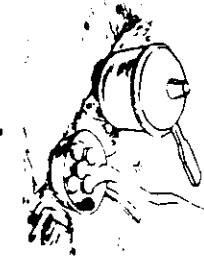
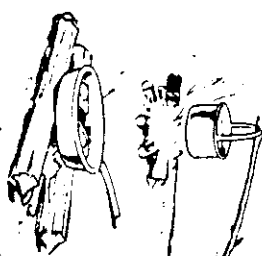

HIKE FIRE
USE ALMOST ANY KIND OF WOOD... KEEP IT SMALL.
TRENCH FIRE
FINE FOR WINDY PLACES OR AREAS OF FIRE DANGER. LIGHTS EASILY.

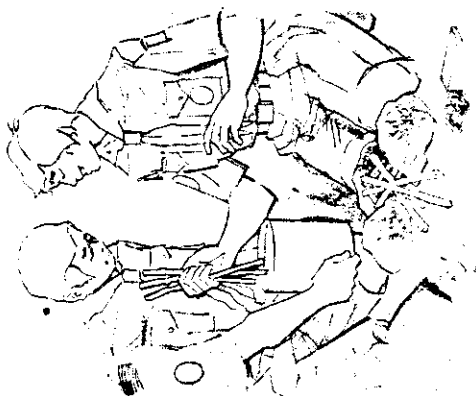

Patrol Teams Informal

WATER-BOILING RACE

Equipment: For each team, one No. 10 tin can (or other size, same for each team), one teaspoon soap powder or detergent, two matches.
Action: In advance of race, whole patrol gathers native tinder, firewood, and three rocks for fireplace. Can is filled with water to within 1 inch of top, with soap or detergent added. Patrol then selects its two representatives. On signal, the two Scouts set up their stone fireplace, lay and light fire, place can of water over fire and keep feeding fire until water boils.
Scoring: First team to get water to boil over wins.
Variation—Have two-man teams start fires by flint and steel or by friction. One log is allowed per team, and wood for fires must be chopped from log during race.

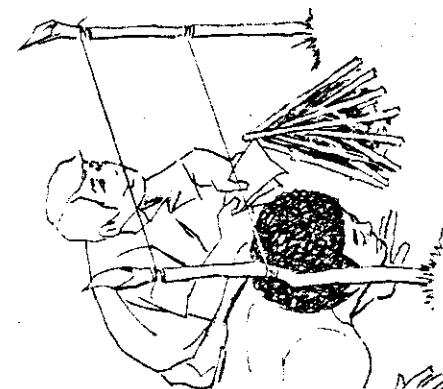

Patrol Teams Informal

STRING-BURNING RACE

Equipment: For each team, two 2-foot sticks, two 3-foot lengths of twine, two matches.
Action: In advance of race, the two sticks are pushed into the ground, 24 inches apart; one piece of string is tied between sticks 12 inches off the ground; the other, 18 inches above ground. Whole patrol gathers native tinder and firewood. Patrol then selects two representatives. On signal, the two Scouts lay the fire (but not higher than lower string) and light it. After lighting, fire must not be touched, nor may more wood be added.
Scoring: That team wins whose fire first burns through the top string.



GAMES—KNOTTING—Five games (plus variations) for patrol teams. For patrol meetings, use half-patrol teams.

Knots Patrol Teams Parallel File

KNOT TYING RELAY

Equipment: One 6½-foot rope per patrol. Scout staff or long stick.

Action: Patrols line up in relay formation, Scout No. 1 about 10 feet from staff, held horizontally thirty inches off ground. On signal "Bowline (or other knot)—Go!" first Scout runs up, rope in hand, ties rope to staff with bowline, has it o.k.'d by judge, unties it, runs back, gives rope to No. 2 who runs up, repeats performance—and so on until eight knots have been tied.

Score: First patrol scores 100 points NOTE—Square knot, sheet bend, fisherman's knot—for these, join ends of rope with taut knot, staff running through loop. Clove hitch, two half hitches, timber hitch—tie rope to staff, pull taut. Taut-line hitch, bowline—tie knots so that staff runs through loop.



Knots Patrol Teams Parallel File

KNOT HOOP RELAY

Equipment: One 6½-foot piece of rope for each patrol.

Action: On the signal "Go," first Scout ties rope into a hoop with a square knot (or sheet-bend, fisherman's knot, or other joining knot) and passes it over his head and down around his body. He steps out of the hoop, unties knot and passes rope to next Scout, who repeats procedure, and so on down the line.

Scoring: First patrol to finish wins. If there are different numbers of boys in the patrols, announce a special number of knots to be tied, such as ten. This will mean that one or more Scouts may have to tie two knots apiece.

Variation: Instead of rope, use pieces of wool yarn. If yarn hoop breaks, it must be tied again—making hoop smaller and therefore more difficult to get through.

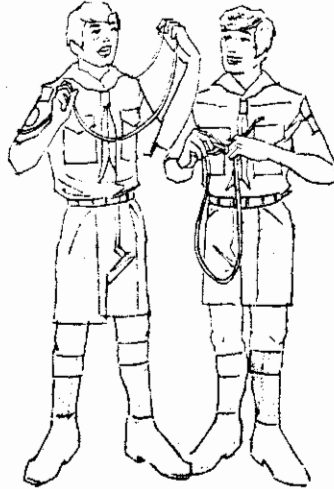

Knots Patrol Teams Facing Lines

BOWLINE—SHEET BEND DRAW

Equipment: One knotting rope at least 6 feet long for each Scout.

Action: Each patrol forms two facing lines. Each player holds rope in right hand, raised above his head. At word "Go," each races to tie bowline around his waist, then joins ropes together with sheet bend. Players lean backward with full weight to test knots.

Scoring: First patrol to have all knots tied correctly and all Scouts leaning backward wins.

Variation—BOWLINE PULL: Players in relay formation. Patrols face each other. Line is drawn down center. Each man is then opposite a player from another patrol on other side of line. At signal, each ties bowline around his opponent's waist and tries to pull him across line. When time is called patrol wins that has most players on its side.

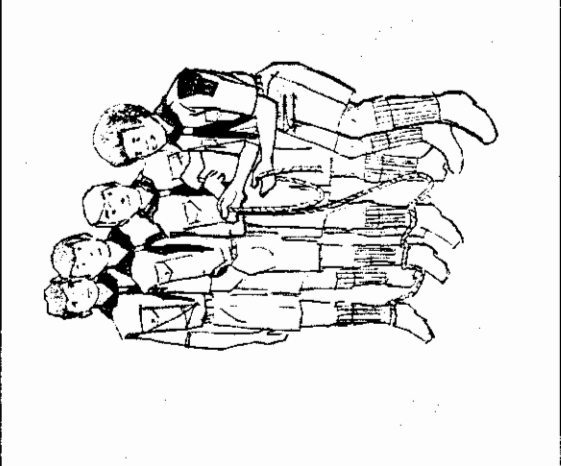
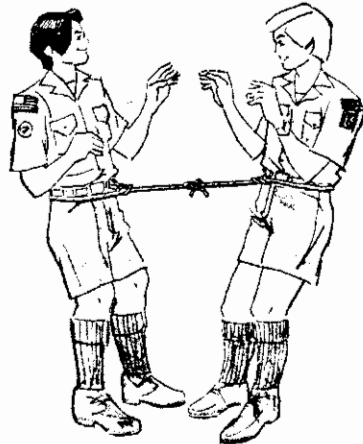

Parallel File
Knots Patrol Teams
CHAIN GANG
Equipment: One rope at least 14 feet long for each patrol.
Action: Patrols in relay formation. At signal "Go," first man ties a bowline around his right ankle and hands long end to next man who ties a clove hitch around his right ankle, and so on down the line until team is "all tied up." Team then races to a finishing line.
Scoring: First patrol to reach finishing line with all clove hitches and the one bowline tied correctly, wins.
Variation: Instead of one long rope per patrol each player has a 4-6 foot rope. Same system as above is used. First boy ties bowline and gives end of his rope to next who ties his rope to lead-off man's with a square knot and then ties a clove hitch around his ankle. When all are tied team "races" to finishing line.

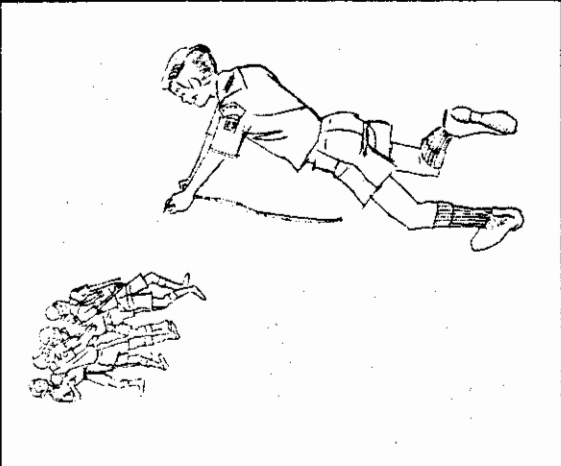

Parallel File
Knots Patrol Teams
RESCUE RACE
Equipment: For each boy, one 4-foot piece of rope.
Action: Patrols line up in relay fashion, each boy with a short piece of rope. Patrol leaders take up position 20 feet in front of first Scout of patrol. Patrol leader is supposedly drowning and must be rescued by having a line thrown to him. At signal, all patrol members tie their ropes into one long line. First boy coils the rope and throws it to the patrol leader and the whole patrol pulls him to shore. It is best to trade patrol leaders around so that no leader is rescued by his own patrol.
Scoring: The object is to get the patrol leader across the line before any other patrol does. Give 100 points for first patrol bringing the leader ashore, 80 points to second, and 60 points to third patrol. Check knots for correct tying. Deduct 10 points for every incorrect knot.

If printed on heavy stock, cut along solid lines to make file cards. If printed on paper, cut apart, paste on file cards to create your SCOUTCRAFTFILE.



GAMES AND CONTESTS—LASHINGS—Games with staves to prepare for pioneering. For patrol meetings, use half-patrol teams.

Lashings Patrol Teams Informal

TRIPOD LASHING

Equipment: For each patrol, three Scout staves or saplings about the same size, one 8-foot length of lashing rope, and one 6-foot length of rope for suspension.

Action: On signal, patrol members lash the three staves or saplings into a tripod using the tripod lashing shown on page 102 of the Fieldbook. When finished, they set up the tripod, tie a bowline in one end of the short rope, and place the bowline loop over the top of the tripod so the free end is suspended down the center of the tripod. Tie a bowline in the free end—high enough so the loop cannot touch the ground. One Scout stands on the bowline loop and holds his balance by hanging onto the line coming down from the top of the tripod.

Scoring: First patrol with a Scout standing in the bowline loop with the tripod supporting his weight is the winner.



Lashings Patrol Teams Parallel File

SNAKE RACE

Equipment: For each patrol, eight staves, seven lashing cords.

Action: Patrol in relay formation places the staves in line between the legs. At signal, the staves are lashed together into a long "snake" with single shear lashings. When secure, the "snake" is passed forward, then up and overhead to rear, down and forward between the legs to the original position.

Scoring: Patrol finishing first wins.



Lashings Patrol Teams Informal

REACTOR TRANSPORTER

Equipment: For each patrol, six Scout staves or saplings about 6 feet long, four 6-foot lengths of cord, 20 feet of binder twine or light cord, one No. 10 can, and one nut for a 1/2-inch bolt.

Action: On signal each patrol builds transporter by lashing a three-sided frame with three staves and then lashing on a tripod from the three corners of the frame. The tin can is suspended from the top of the tripod. Nut is also hung from the top of the tripod. It hangs down in the can but does not touch the bottom or the sides. When finished, three patrol members pick it up by the three corners and carry it to a finish line at least 100 feet away. If nut swings and hits side of can, patrol must return to starting line and start carry again. Object is to transport reactor so gently and evenly that it is not jarred.

Scoring: First patrol across lines wins.

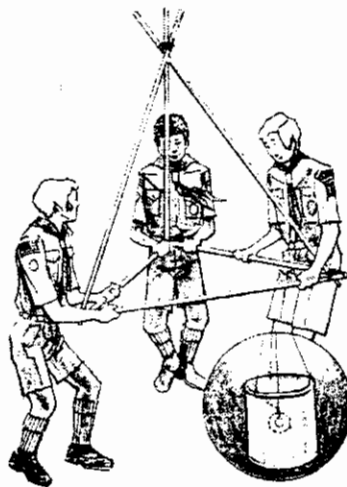

Informal

Patrol Teams

Lashings

FLAGPOLE RAISING

Equipment: For each patrol five Scout staves, one patrol flag, eight pieces of sash cord to tie four double lashings, three wooden stakes, one mallet for driving stakes, and three guy ropes about 18 feet long.

Action: Patrol lines up with four Scout staves and the patrol flag attached to the fifth staff. On signal, the Scouts lash the five staves together omitting frappings. Next, they attach three guy lines about two-thirds of the way to the top; raise the pole and stake down the guy lines, so the pole stands vertically. When finished, patrol forms single line at base of pole and comes to attention. Scoring: First patrol finished wins. Give extra points for tallest pole.

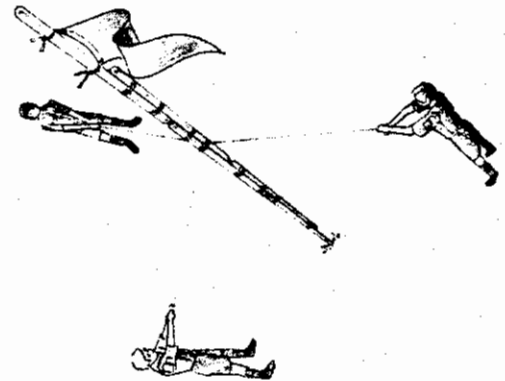

Informal

Patrol Teams

Lashings

ROMAN CHARIOT RACE

Equipment: For each patrol six Scout staves, nine pieces of sash cord for lashings. Action: Equipment is placed in piles opposite patrols. On signal, patrols run and lash "chariot." This done by making a trestle frame, as in building a bridge. Four staves form a square; the fifth and sixth staves are lashed diagonally to opposite two sides. When frame is finished, two Scouts pull "chariot" and rider down the field around a marker and back to finish line. Scoring: First patrol at finish with "chariot" intact wins.

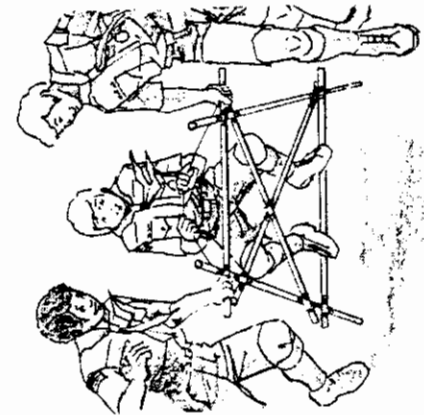



TROOP MEETINGS—CEREMONIES for opening and closing troop meetings. Themes: U.S. flag, knots, conservation.

MEETING CEREMONIES— OPENING, CLOSING

Keep interest in conservation alive by emphasizing in ceremonies and otherwise.

CONSERVATION OPENING CEREMONY.

Equipment: Code of Outdoor Manners on poster on wall of meeting room. Have troop artist design a poster from page 62, Scout Handbook.

Formation: Troop in line, facing Code.

Program: Senior patrol leader: "Scout Sign! Repeat after me: 'As an American, I will do my best to BE CLEAN in my outdoor manners, BE CAREFUL with fire, BE CONSIDERATE in the outdoors, BE CONSERVATION-MINDED.'"

CONSERVATION CLOSING CEREMONY.

Equipment: Code poster, pencils.

Program: Each Scout comes to Code poster, pledges himself by personal signature to live up to Outdoor Code.

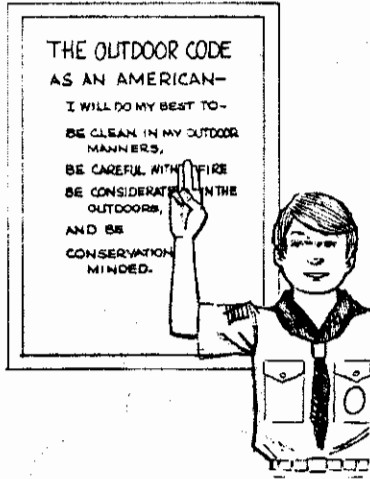

MEETING CEREMONIES— OPENING

Start troop meetings with a ceremony based on spirit and skills such as:

SQUARE KNOT—SCOUT LAW OPENING CEREMONY.

Equipment: Each Scout has a 6½-foot belt rope, each patrol its patrol flag.

Formation: Scouts form by patrols in circles around their patrol flags, each boy with his rope, patrol leader holding flag.

Program: At command of senior patrol leader, "Tie bowlines around patrol flag staff," each Scout in turn ties his rope around flag staff and returns to his position in circle, holding on to free end of his rope. When all ropes are attached, the Scoutmaster says: "These ropes, joined to the patrol flags with a knot that will not slip, symbolize your patrol unity. Let us repeat together the Scout Law expressing the spirit of our patrols.—Scout Sign!—A Scout is Trustworthy, Loyal, Helpful. . . ."

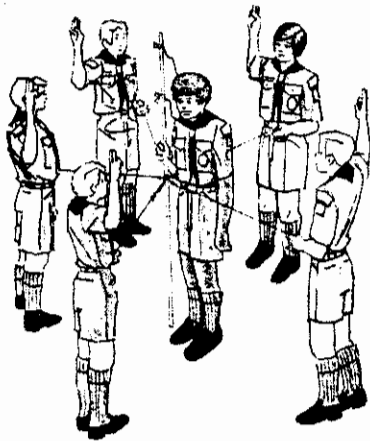

MEETING CEREMONIES— CLOSING

Carry the theme of the troop meeting's opening ceremony over into the closing ceremony, to tie the parts of the meeting into a unit.

SQUARE KNOT—SCOUT OATH CLOSING CEREMONY.

Equipment: Each Scout has 6½-foot belt rope.

Formation: Whole troop forms large circle, each Scout with his rope behind him.

Program: Senior patrol leader directs: "Tie one end of rope to end of rope of the Scout on your right, with square knot. Grasp rope with left hand; make circle as large as ropes permit."

When command is carried out, Scoutmaster says: "We are bound together in a circle of ropes tied by the square knot which represents the brotherhood of Scouting. While in this circle, let us rededicate ourselves to the Scout Oath.—Scout Sign.—On my honor, I will do my best. . . ."

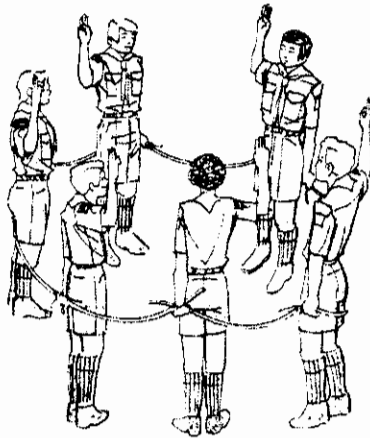

MEETING CEREMONIES - Closing

U.S. Flag Ceremony, Scoutmaster's Handbook (SMH), 290

Taps Ceremony, SMH, 289

Scout Vesper Song Ceremony, SMH, 290

Scout Law Ceremony, SMH, 290

Scout Benediction Ceremony: Troop in circle formation.

Scoutmaster: "May the Great Master (all make gesture toward heavens) of all Scouts (inclusive gesture from right to left at height of shoulder) be with you till we meet again (right hands being brought to heart and heads bowed)."

America Yell Ceremony: Troop in circle formation.

Close with America Yell: "A-M-E-R-I-C-A, Scouting, Scouting, U.S.A." followed by Sky Rocket Yell: "Ssss" (the hiss of the rising rocket) "Boooooom" (the bursting rocket) "Ah-h-h" (the soft exclamation as rockets spread) (then the terrific boy-satisfying yell: "SCOUT!") "Scr-r-r-atch"

MEETING CEREMONIES - OPENING

U.S. Flag Ceremonies, Nos. 1, 2, and 3: Scoutmaster's Handbook,

288-89

Troop Flag Ceremony 1

Scouts in circle formation, troop flag in center. The Scouts salute and repeat after the SPL troop's special pledge, along this line: "As a member of Troop One, I pledge that I shall always strive: To be a good member of my patrol - To take part in all troop activities - To advance in Scoutcraft - To act as a Scout at all times."

Troop Flag Ceremony 2

Form the patrol as spokes in a wheel, facing troop flag in center. Patrol leaders hold onto the flagpole with both hands. Behind them, their Scouts place their hands on the shoulders of the boy in front of them. The troop sings an appropriate Scout song, such as "Hail, hail, Scouting Spirit" or "Trail the Eagle."



GAMES AND CONTESTS - COMPASS and MAP I - Preliminaries before using map and compass together in games and contests.

COMPASS and MAP—Make map speak compass language

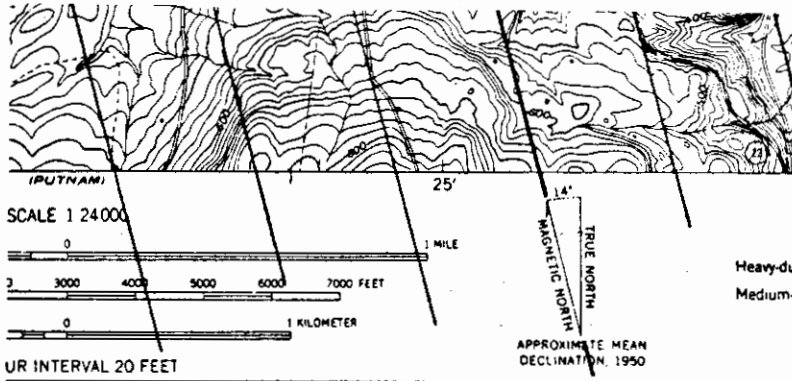

By making map speak compass language you eliminate all resettings of compass because of magnetic variations. Make your map speak compass language by providing it with

magnetic-north lines. Just continue the magnetic-north half arrow across the map. Then draw the other lines parallel to it a ruler's width apart.

COMPASS and MAP—Orienting map

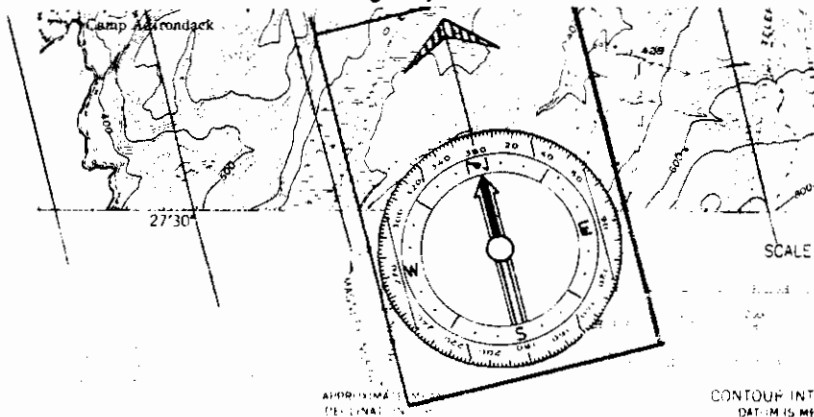

Set the compass dial so that N is opposite the direction-of-travel arrow. Place the compass on the map with the base plate

parallel with the magnetic-north lines. Then turn map and compass until the red end of the compass needle points to N.

COMPASS and MAP—Determining degree directions on map

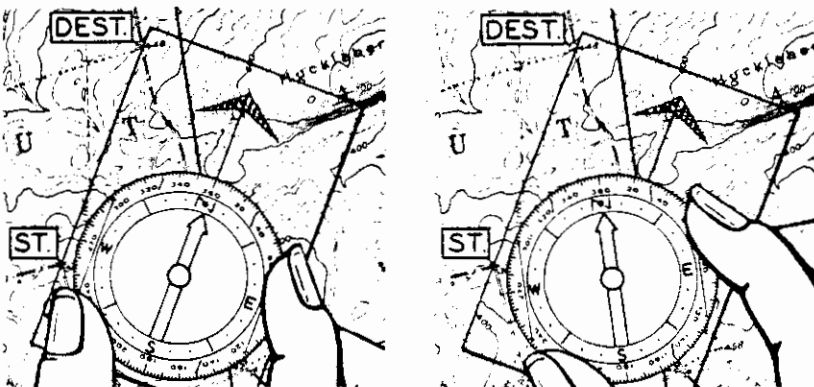

Step 1 in Orienteering: On a map, line up edge of compass baseplate with route from start (ST.) to destination (DEST.).

Step 2 in Orienteering: On compass, set the dial by aligning orienting arrow and lines with magnetic-north line on the map.

(Steps 1 and 2 in Orienteering)

COMPASS—Following degree directions in the field

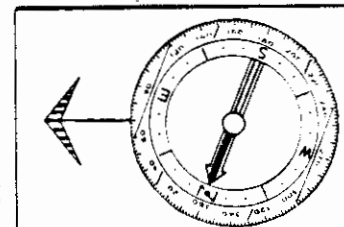

Step 3 in Orienteering: In the field, follow direction set on the compass. Hold compass level in hand. Turn yourself until red end of compass needle points to N on the dial.

COMPASS—Determining degree directions in the field

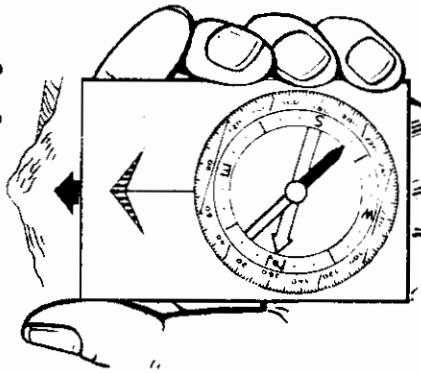

To find direction with an orienteering compass, point direction-of-travel arrowhead toward landmark. Turn dial until

COMPASS—Determining degree directions in the field

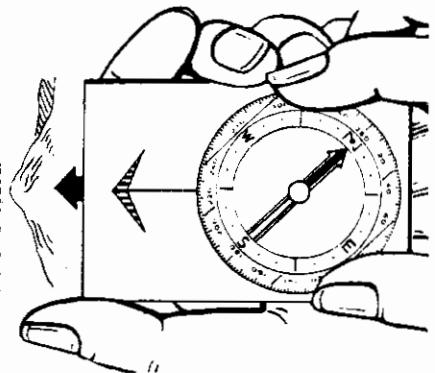

compass needle lies over the orienting arrow. Bearing to hill in this case is 225°.



GAMES AND CONTESTS—COMPASS and MAP

II—Three outdoor and two indoor games for troop or patrol meetings, hikes.

Compass Patrol Teams Informal

SILVER DOLLAR HUNT

Equipment: For each participant 1 orienteering compass, one fake "silver dollar" (3-inch circle from tin can top), one card with distances and directions, such as "50 steps X degrees (X being less than 120°) - 50 steps X+120 degrees - 50 steps X+240 degrees."

Action: Scatter participants over field with fairly tall grass. Place a "silver dollar" at the feet of each Scout. On signal "Go," each Scout sets his compass for direction on his card and walks the specified distance. The same for second and third bearings. When done, the "silver dollar" should be at his feet (or at least within his immediate sight).

Scoring: Patrol with most Scouts winding up within 7½ steps of their "silver dollars" (5 percent error) wins.



Compass Patrol Teams Informal

BLINDFOLD COMPASS WALK

Equipment: For each patrol, eight small, numbered stakes, set in ground 5 feet apart in a north-south line. For each Scout: 1 Polaris or other orienteering compass, and one large paper bag.

Action: One Scout from each patrol stands at each of the eight stakes. Scouts from one patrol set their compasses at degrees between 45° and 135°; boys from opposing patrol between 225° and 315°. Paper bag is then placed over head of each Scout, making him just able to see ground and compass in his hand. Each Scout turns around 3 times, then follows bearing on his compass for 100 steps. He then turns around and follows back bearing (orienting arrow pointing toward him instead of away from him) for 95 steps. Only Scouts within 10 steps of their marker score.

Scoring: Patrol with most scoring boys wins.



Compass Patrol Teams Informal

DIRECTION HUNT

Equipment: Eight (or more) tall stakes provided with pointers and pointing to distant landmarks or clearly identified objects (large tree, large rock, etc.). Each participant has Polaris or other orienteering compass, pencil and paper.

Action: Scouts from each patrol distribute themselves at the different stakes. They check landmarks to which markers on stakes are pointing, set their compasses for the degree directions to the landmarks and write them down. The Scouts then move to next pointer and determine next degree direction. At end of specified time, each Scout turns his findings over to judge.

Scoring: Patrol with most correct degree directions (within 10°) inside time limit wins.

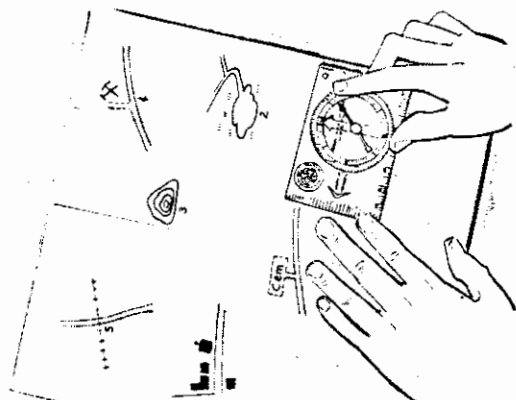

Map and Compass Patrol Teams Parallel File

DIRECTION FINDING RELAY

Equipment: For each patrol, a map, a compass, and eight cards. On each card is written the names of two towns (or other points).

Action: Patrols in relay formation. Fifteen feet in front of patrol is their map and cards. At signal "go" first Scout runs up, selects a card and determines the compass direction from first point mentioned on card to second. Scout writes this direction on his card and hands it to leader assigned to his patrol. He then runs back to his patrol, touches off next Scout.

Scoring: 10 points if within 5° of being correct. 5 points if within 10°.

Variation—MAP ORIENTING: First Scout runs up to map, orients it, using compass. He returns to touch off second Scout. Meanwhile leader checks orientation, and spins map around, for the second Scout.

Map and Compass Patrol Teams Parallel File

MAP SYMBOL RELAY

Equipment: Several identical sheets of paper with numbered map symbols—including contour lines—drawn on them. See Scout Handbook.

Action: Patrols line up in relay formation facing opposite wall upon which map symbol sheets (one for each patrol) have been posted. On signal, first Scout runs up and names the first symbol and runs back and touches off the next Scout who runs up and names the second symbol. Continue the relay until all symbols have been named.

Scoring: Score 2 points for each symbol correctly named and subtract 1 point for each symbol incorrectly named. Add 10 points for the patrol that finishes first.

Maps Patrol Teams Parallel File

Maps

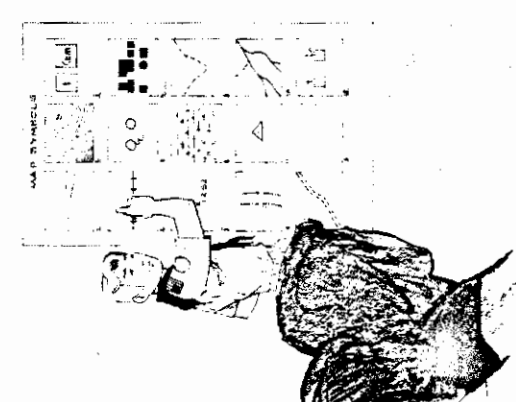

COMPASS INSTRUCTION DEVICE

Get SILVA demonstration compass from the Supply Division or make one.

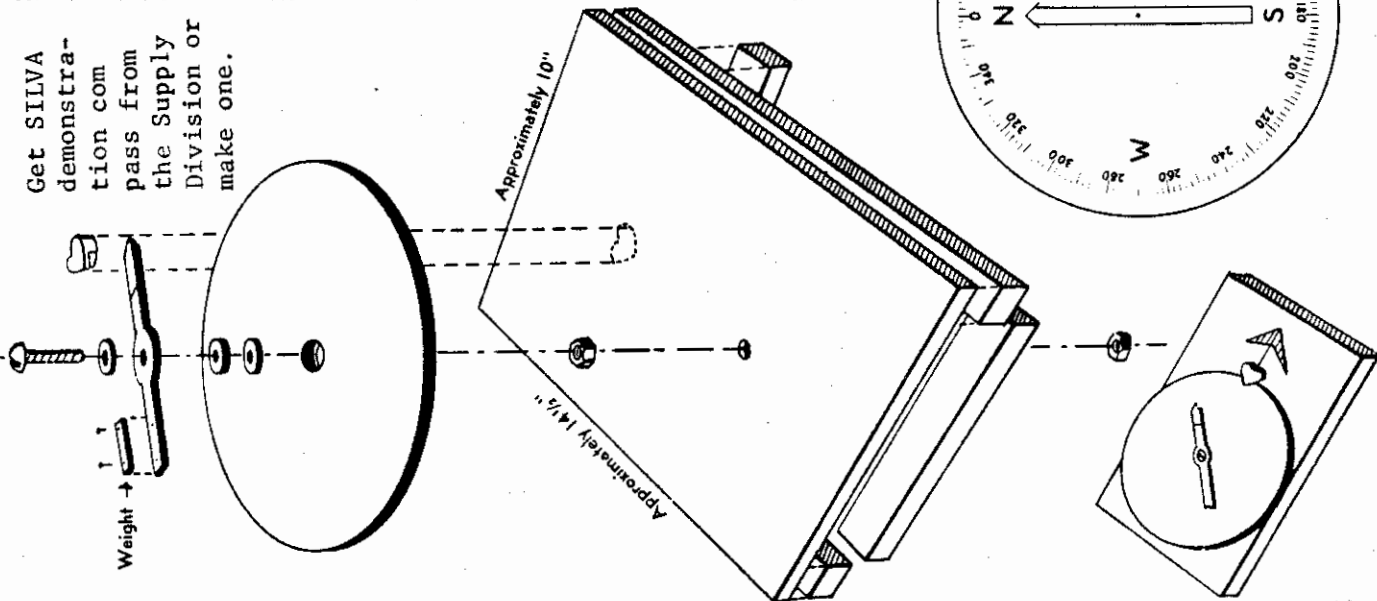

VARIATIONS MAP

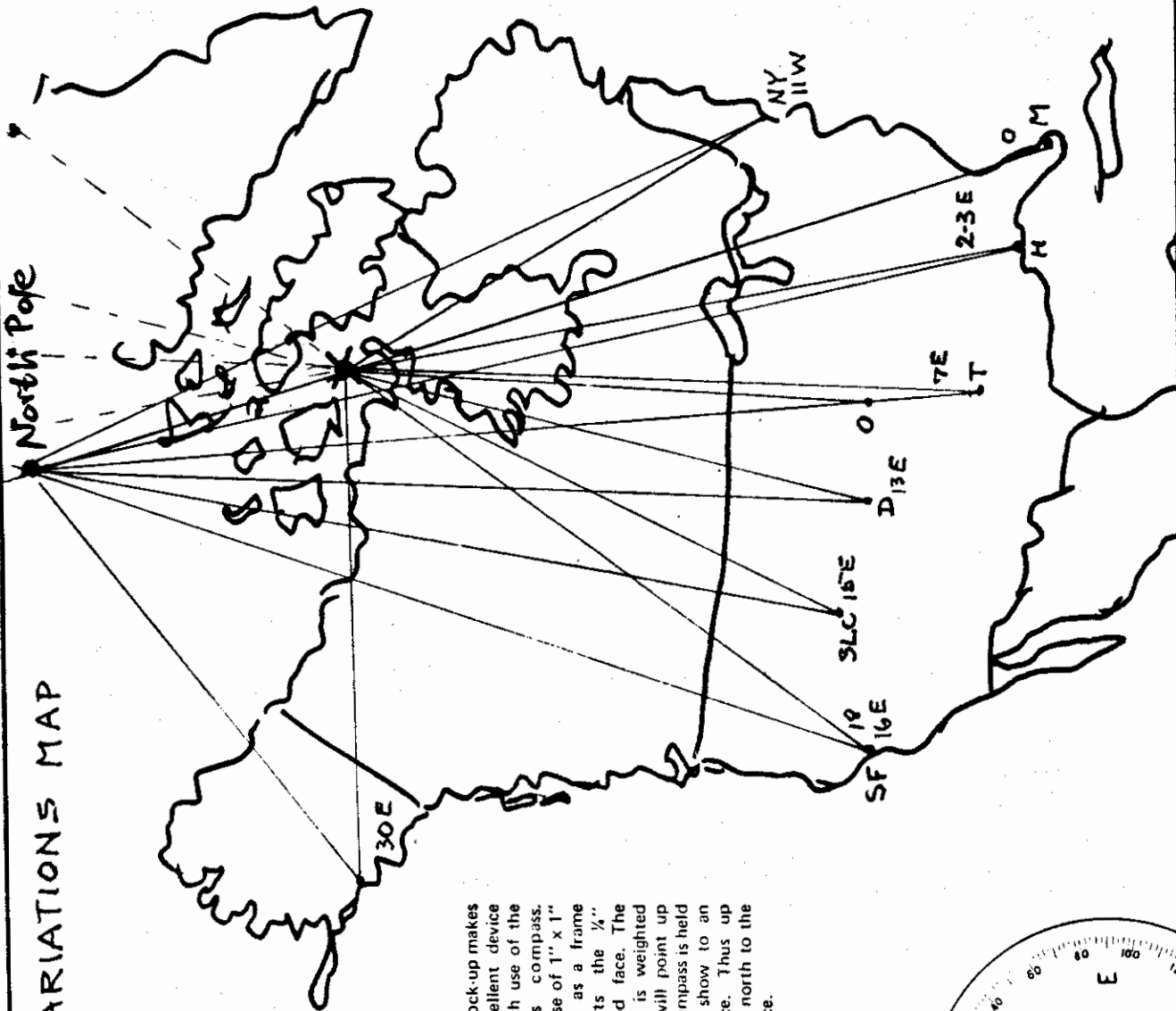

This mock-up makes an excellent device to teach use of the Polaris compass. The base of 1" x 1" lumber as a frame supports the 1/2" plywood face. The needle is weighted so it will point up when compass is held up to show to an audience. Thus up will be north to the audience.

When demonstrating, hang up map so that your local magnetic north line is perpendicular. Set demonstration compass with N of compass housing at base of direction-of-travel arrow.



GAME LEADERSHIP—General suggestions. Troop games arranged according to formations. Silent signals.

GAME LEADERSHIP

In advance of running game: Choose the right games: To fit group as to degree of strenuousness. To fit the game area: small, medium, large To fit the mood: some games for fun and fitness, some for skill practice, some vigorous, some quiet

Running the game:

- 1. Name the game so boys will remember for next time. 2. Get patrols into formation: line, relay, circle 3. Explain the rules - Make it short and clear. 4. Demonstrate the game - If a relay, have first boy of each team perform; if line game, go through motions. 5. "Any questions?" - Give the boys a chance to get explanation to points which may not be clear to them. 6. Run the game - with needed equipment, judges ready. 7. Recognize the winners with patrol cheers.

TROOP GAMES I - Arranged according to formations. (Games listed here are for FUN and FITNESS. For skill games, see appropriate Gamefile card sheets.)

Single Line Formation - Whole troop against "It" BRITISH BULLDOG (Scoutmaster's Handbook, SMH, 304 and Gamefile card) DO-THIS-DO-THAT SMH, 303)

Facing Lines Formation-Half-troop teams BALL OVER (Gamefile card) STEAL BACON (SMH, 304) CROWS AND CRANES (SMH, 305)

Circle Formation - Whole troop WHIPPED TO THE GAP or SWAT 'Em (Gamefile card; SMH, 303) JUMP THE SHOT (SMH, 302) POISON (SMH, 303)

Nonformation - Scouts spread out NUMBERS (Gamefile card) BARNYARD (Gamefile Card) SPUD (SMH, 304)

TROOP GAMES II - Arranged according to formations. (Games listed here are for FUN AND FITNESS. For skill games, see appropriate Gamefile card sheets.)

Parallel File Formation - Patrol teams LUCK RELAY-IZZY-DIZZY RELAY-GRASSHOPPER RELAY (Gamefile card: Fun Relays) CATERPILLAR RELAY (Gamefile card) MIXED RELAY (Gamefile card) HORSEBACK RELAY (Gamefile card) WHEELBARROW RELAY (Gamefile card)

Duel Formation - Competing patrol representatives INDIAN HAND WRESTLING (SMH, 307 and Gamefile card) INDIAN LEG WRESTLING (SMH, 307 and Gamefile card) INDIAN ARM WRESTLING (Gamefile card) STICK FIGHT - STICK TWIST (Gamefile card) THE STRUGGLE - WRIST PUSHING (Gamefile card)

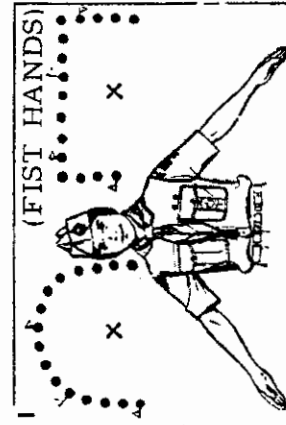

COUNCIL OR "U" FORMATION



"HALT"

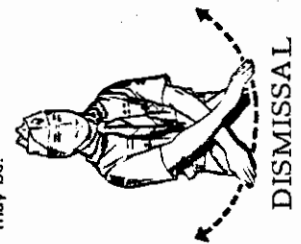

DISMISSAL

SILENT SIGNALS for Troop Formations I

Method: Senior patrol leader gives 6 to 10 silent signals, one after the other: attention, single lines, troop circle, dismissal, parallel file, etc. Patrol leader gets into formation first. Patrol forms next to him or behind, as the game may be.

SINGLE RANK FORMATION

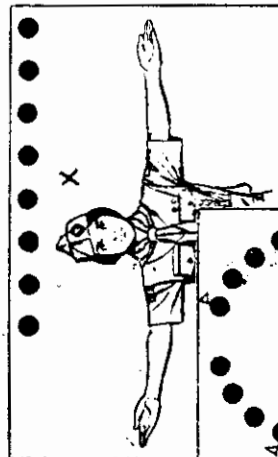

TROOP CIRCLE FORMATION

SILENT SIGNALS for Troop Formations II

For DOUBLE LINE FORMATION, use same signals as for Single Line, but with hands fist. Half of patrols form in front of the senior patrol leader, facing him, other half behind him.

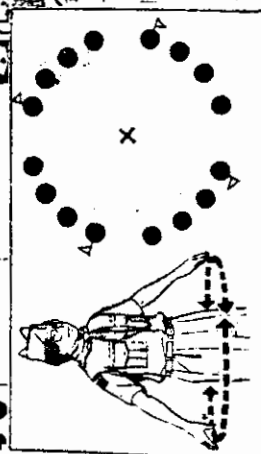

RELAY FORMATION

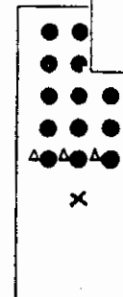

If printed on heavy stock, cut along solid lines to make file cards. If printed on paper, cut apart, paste on file cards to create your SCOUTCRAFT FILE.



GAMES—FUN AND FITNESS—Troop meeting games—three for fun and fitness, two for fun ("confusion" games).

Fitness and Fun Whole Troop Single Line
BRITISH BULLDOG

Equipment: None
Action: Troop lines up along one side of room. One player takes position in center of room facing the troop. At "Go," entire troop charges and tries to reach other side of room, without being caught. To catch someone, "bulldog" in center must lift player off floor long enough to yell "1-2-3 British Bulldog!" A caught player becomes one more "bulldog" for next charge. Not more than three bulldogs can tackle a player. If a struggling player is not lifted completely off the floor while whole troop slowly counts to 10, he is declared free and joins troop for next charge. Game is run until everyone has been caught.
Scoring: Last man caught is the winner.

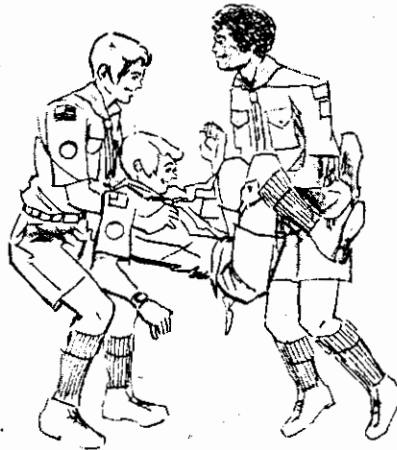

Confusion

Whole Troop
BARNYARD

Equipment: Slips of paper with names of animals. Each name appears on two slips.
Action: The slips of paper are put into a hat. When everyone has a slip, each Scout starts making the animal sound that is appropriate to the animal name on his slip of paper. The object of this game is for each boy to find his "mate" who is making the same animal call as he. When a Scout finds his mate, both stop calling and step to one side.
Scoring: None. This is strictly for fun.
Variation—BARNYARD SURPRISE: To add some fun to this game, make one slip with the name "donkey." The hee-hawing at the end by one lone Scout will make everyone laugh.

Fun

Fitness and Fun Facing lines
Half Troop Teams
BALL OVER

Equipment: Ball, about basketball size; whistle.
Action: Line is drawn across game area. One team on either side of line. Players take positions at various points on their side of line. Players cannot cross line. One Scout with a whistle is blindfolded. When he blows whistle, leader puts ball into play. Object of game is to keep the ball in the opposing team's territory. Whistle should be blown frequently.
Scoring: One point is counted against the side that has the ball when whistle is sounded. At end of game side with lowest score wins.



Confusion

Whole Troop
NUMBERS

Equipment: None.
Action: Scouts are scattered throughout room. The leader says, "Form fives" (or fours, or threes, or twos). Scouts have to get into groups of whatever size is announced. Those who don't get into a group of correct size are out of the game.
Scoring: Last two Scouts remaining in the game are the winners.
Variation 1: On leader's command "Sit in fives," Scouts try to sit down in groups of five or whatever number was called. Should the leader say "Stand in fives," nobody moves. Those who sit at that command, drop out.
Variation 2: Whenever a number is mentioned by the leader in telling a story, the Scouts all sit down. Last Scout to sit down drops out of the game. Game ends when only one Scout remains—the winner.

Fun

Fun Whole Troop Circle
SWAT 'EM OR WHIPPED TO THE GAP

Equipment: Newspaper rolled up into swatter.
Action: Troop in circle formation, with all players facing in, hands on back. Game leader walks quietly around outside of circle and places newspaper swatter secretly in the hands of one of the players. Player with swatter starts hitting player to his right with swatter. He continues swatting while victim runs around outside of circle and back to his place in the ring. Player with swatter now goes around circle (his place in the ring has been taken by the first leader) and hands swatter to another player. Game is continued as long as desired.
NOTE: If troop is large, use two or three swatters.

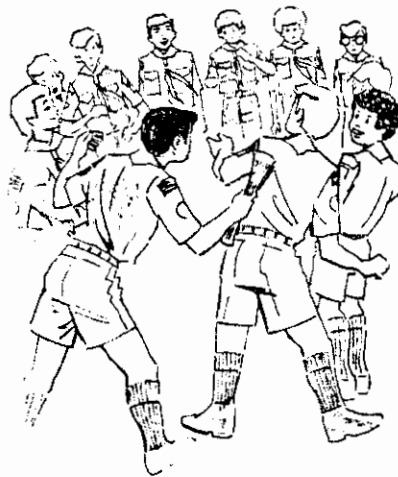



GAMES—FUN AND FITNESS—Five relay games of patrol teams. At patrol meetings, use half-patrol teams.

Fun Patrol Teams Parallel File

FUN RELAYS

For a fun session at troop meeting, use a series of relay games. In each case, patrol runs eight runners.

LUCK RELAY: In front of each patrol is a junior leader with a coin in one hand. First Scout runs up, guesses in which hand coin is. If wrong, he continues running up until he guesses correctly, leader changing coin position at will. If correct, he returns to patrol and touches off next Scout.

IZZY-DIZZY RELAY: First runner runs up to a line, puts one finger on floor, and circles around finger seven times, then races back and touches off second Scout, and so on.

GRASSHOPPER RACE: Runner hops to line and back with Scout cap between his knees.

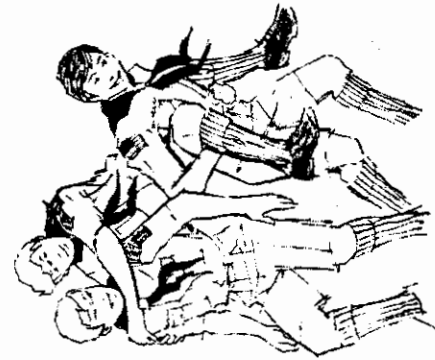

Fun Patrol Teams Parallel File

MIXED RELAY

Equipment: None.

Action: Patrols line up at starting line in relay formation. At signal, Scout No. 1 runs to wall, touches it, and returns to touch off Scout No. 2. Scout No. 2 holds one foot and hops on the other to the wall and returns to touch off Scout No. 3 who runs backward to the wall and back. Scout No. 4 jumps sideways to the wall and returns to touch off Scout No. 5 who runs to the wall and back on hands and feet. Scouts Nos. 6 and 7 then form a "chair" with their hands and carry Scout No. 8 to the wall and back. Scoring: First patrol completing the course is the winner.



Fun Patrol Teams Parallel File

HORSEBACK RELAY

Equipment: None.

Action: Patrols line up in relay formation with smallest member of each patrol at the front of his patrol line. On starting signal, he jumps up on back of second Scout in line and the two race around a mark set about 20 feet in front of the patrol. As soon as they reach the starting line, the "rider" must transfer to the next Scout in line without touching the floor. If he touches the floor in making the transfer, he must get back on the "horse" that just took him over the course and ride around again before making the transfer. This continues until the rider has made the rounds riding on each Scout in the patrol. If patrols are less than eight, the first horses will have to repeat to make a total of seven laps. Scoring: First patrol to complete seven laps of the course is the winner.

Fun Patrol Teams Parallel File

CATERPILLAR RACE

Equipment: None.

Action: Patrol members line up single file behind starting line. Put one chair for each patrol about 25 feet from the starting line. The first Scout in each patrol places his hands on the floor. Other Scouts bend down and grasp the ankles of Scouts in front of them. On signal, patrols move forward, swing around chair, and return to the starting line. The first Scouts must walk on hands and feet throughout. If the line is broke, team must stop and re-form line before continuing.

Scoring: Team finishing first is the winner.

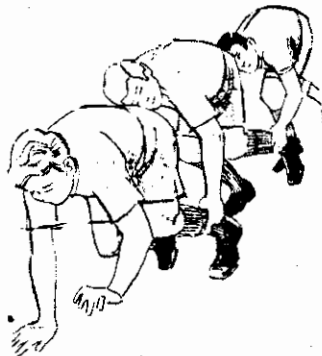

Fun Patrol Teams Parallel File

WHEELBARROW RELAY

Equipment: None.

Action: Establish a starting line and, 20 feet away, a turning line. Patrols line up in relay formation at starting line. On signal, first Scout from each patrol places hands on the floor and the second Scout grasps his ankles and lifts his legs. In this position they travel to the turning line, the first player traveling on his hands. On reaching the turning line, they reverse positions and return, touching off the second pair of Scouts who follow the same procedure. Relay is continued until all patrol members have competed. Scoring: Patrol finishing first is the winner.



CAMPFIRES—CAMPFIRE LEADERSHIP and SONG LEADERSHIP. General suggestions. Lists of songs to fit moods.

SONGS - As the flames leap high I
(Numbers refer to pages, *Scout Songbook*, No. 3224)

Lively songs

- I'm Happy When I'm Hiking (65)
- The Happy Wanderer (80)
- Vive l'Amour (124 and Campfire Helps III)
- Quartermaster's Store (36)
- I've Been Working on the Railroad (35)
- You Can Dig My Grave (96)
- I'm a Something (Campfire Helps III)

Scouting Spirit

- I've Got That Scouting Spirit (54)
- Be Prepared (56)
- Trail the Eagle (59)
- Hail! Hail! Scouting Spirit (67)
- Scouting We Go (67)

SONGS - As the flames leap high II
(Numbers refer to pages, *Scout Songbook*, No. 3224)

Action Songs

- If You're Happy (16)
- Duke of York (Campfire Helps III)
- Little Scouting Light (Campfire Helps III)
- My Bonnie Lies Over the Ocean (Campfire Helps III)
- Alouette (90 and Campfire Helps III)
- She'll Be Coming 'Round the Mountain (14)

Rounds

- The Paddle Song (28)
- Row, Row, Row Your Boat (30)
- We're on the Upward Trail (56)
- Munching Mangoes (file card)
- Aunt Jemima (file card)

SONGS - As the fire burns low
(Numbers refer to pages, *Scout Songbook*, No. 3224)

Old quiet favorites

- There's a Long, Long Trail (121)
- He's Got the Whole World in His Hands (102)
- Jacob's Ladder (97)
- My Father's House (119)
- Home on the Range (75)
- Down in the Valley (99)

Patriotic songs

- God Bless America (45)
- America, the Beautiful (46)

Closing songs

- By the Blazing Council Fire (126)
- Scout Leader's Prayer (55)
- Scout Vesper (125)
- Kum Ba Yah (108)
- On My Honor (63)
- Taps (126)

SONG LEADERSHIP

Select songs to fit audience. Choose songs to fit a mood or to establish one.

If song is known: Announce the song. Set pitch and hum or sing a line. Start song with a "Let's go!" or clap of hands. If pitched too high or too low, stop, start again at correct pitch.

If song is not known: Sing a verse to establish tune and words. Repeat words only. Repeat song, having audience join as they pick up the tune. Repeat until learned or while interest is shown.

Give beat of song while singing. Use a simple up-and-down motion of one or both hands.

Indicate volume of singing desired by vigorous or languid motions or raising or lowering of hands. Indicate by hand movement notes to be prolonged.

CAMPFIRE LEADERSHIP

Follow campfire program worked out in advance and put in writing, with leadership assigned.

Solemnity: Ceremony for starting campfire officially. Scoutmaster's minute and/or songs of patriotic or inspirational flavor for closing.

Songs: Follow the fire in selection - lively songs while flames leap high, quiet songs as fire burns low. Make use of patrol members to lead.

Stunts by whole group: Claps, cheers, action songs.

Skits by whole patrols or by a number of actors.

Showmanship throughout: Lighting of fire by special method. Costumes (improvised) for skits. Fire itself: Have close rapport between campfire leaders and campfire tenders, with signal for "More light" for lively songs and skits, for "No more fuel" as end of campfire draws near.

If printed on heavy stock, cut along solid lines to make file cards. If printed on paper, cut apart, paste on file cards to create your SCOUTCRAFT FILE.



CAMPFIRES—CEREMONIES, GAMES—Lighting methods. Openings, closings. Campfire fun games.

CAMPFIRE OPENINGS

As the flames point upward so be our aim.
As the red logs glow so be our sympathies.
As the gray ash fades so be our errors.
As the good fire warms the circle, so may our ideals warm the world.
I now declare the campfire open.

Spirit Red, Spirit Red - thy hunger must be fed.
Spirit Hot, Spirit Hot - forget us not, forget us not.
As the year grows old, keep us from the cold.
Spirit White, Spirit White - in the darkness of the night, be our shining light.
I now declare the campfire open.

CAMPFIRE CLOSINGS

Scout Vesper: "Softly falls..." (Scout Songbook, 125)
On My Honor (Scout Songbook, 63)
Taps (Scout Songbook, 126) Start with arms lifted high, lower them slowly as song progresses.
Scout Benediction
"And now may the Great Master of all Scouts be with us till we meet again."
Campfire leader (makes Scout sign): "Be Prepared!" Scouts (make Scout sign): "We are prepared!"

CAMPFIRE - Lighting

By Candle representing the "Spirit of Scouting."
By Torch brought in by Indian runner.
Indian-style by fire-by-friction (Fieldbook, 312)
Pioneer-style by flint-and-steel (Fieldbook, 310)
By Fire Snake (Patrol and Troop Activities, 128)

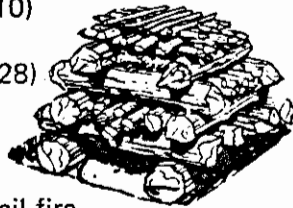

See Fieldbook, page 120, for details on council fire.

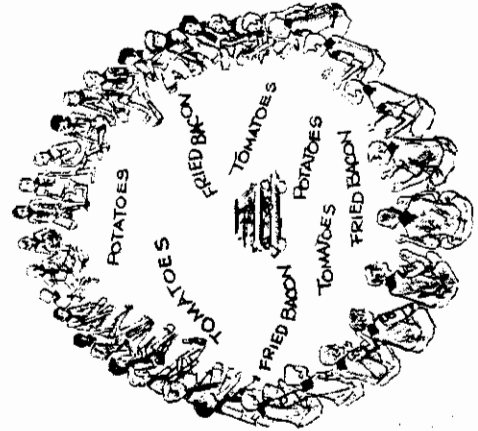

CAMPFIRE GAMES

LAUGHING GAME: The first player in the circle says, "Ha." The next says, "Ha, ha." The third must say, "Ha, ha, ha." This goes on, each player adding a "ha" until one makes a mistake or laughs out of turn. The victim must sing a solo.
THE FROG POND: Divide the Scouts into three groups. Have the first group say in high voices, "Tomatoes, tomatoes, tomatoes." The second group in deeper voices says, "Potatoes, potatoes, potatoes." The third group in deep bass voice, "Fried bacon, fried bacon, fried bacon." After rehearsing each group, turn them loose at once; continue until signal for silence.
CHALLENGES: At campfire, one patrol may challenge another to compete in one of the many strength tests or interpatrol contest events. Dog fight, leg wrestling, and other competitions are good examples. The winner is the champion of the evening.

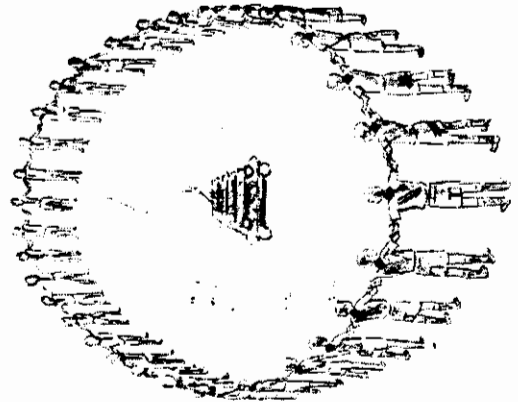

CAMPFIRE CEREMONIES

Make it a tradition to light the campfire by fire-by-friction or fire-by-flint-and-steel, during complete silence.
Openings: 1. Campfire leader points to compass directions, and says: "From the North, from the South, from the East, from the West, may good luck come to us always. I now declare the campfire opened."
2. "This be our challenge: Sparks that upward fly! So may our hearts be gay, and spirits high! Our campfire is opened."
3. "Now, as our thoughts are kindled with the flames, so let our prayers go out through all the world. Our campfire is opened."
Closings: 1. Sing "Taps"—raising the arms slowly to "... from the sky," then lowering them again.
2. Circle, arms around shoulders. Sing "By the blazing council fire's light."
3. Troop hums "Taps" while a single Scout recites Scout Oath.

If printed on heavy stock, cut along solid lines to make file cards. If printed on paper, cut apart, paste on file cards to create your SCOUTCRAFTFILE.



CAMPFIRES—SONGS—Action songs, rounds and trick songs. Also suitable for troop meetings.

SONGS - Action Songs

DUKE OF YORK

The good old Duke of York, he had ten thousand men. He marched them to the mountain top and marched them down again.

And when he was up, he was up.

And when he was down, he was down.

And when he was only half way up he was neither up nor down.

Motions: 1. (Begin by sitting) On "up," stand up. On "down," sit down. On "Half way up" squat half-way up.

2. (Begin by standing) Do things opposite: On "up," sit down. On "down," stand up.

3. (Divide into two groups, one sitting, one stands) Motions as in both 1 and 2 together.

SONGS - Action Songs

LITTLE SCOUTING LIGHT

1. This is my little Scouting light (hold up index finger) I'm going to let it shine (three times)

Let it shine, let it shine, all the time.

2. Carry my light around the block (move index finger in circle).

3. Cover my light with a basket? NO! (cover finger with other hand cupped; lift abruptly at NO!)

4. Don't you blow my little light out (instead of singing "blow," go "Puff")

MY BONNIE LIES OVER THE OCEAN

Stand up for 1st B (in Bonnie), sit down for 2d B. Continue same way throughout song. Most fun comes from line "Bring back, bring back, oh bring back my Bonnie to me."

SONGS - Rounds

MUNCHING MANGOES (to tune of Are You Sleeping?)

Munching mangoes, munching mangoes.

Mish mush mash - mish mush mash.

Jump into the river - jump into the river.

Splish splosh splash - splish splosh splash.

(emphasize the Splash with a loud clap)

AUNT JEMIMA (to tune of Soldiers' Chorus from Opera Faust with fourth line distorted)

Aunt Jemima, look at your Uncle Jim.

He is in the duck pond, learning how to swim.

Now he does the backstroke, now he does the side.

Now he's in the water, swimming against the tide.

(emphasize with swimming strokes)

SONGS - Trick Songs

I'M A SOMETHING

(A song with unexpected ending, to tune of Clementine)

I'M A SOMETHING

(A song with unexpected ending, to tune of Clementine)

1. I'm a blood stain, I'm a blood stain, I'm a blood stain, yes I am.

And I'd rather be a blood stain - than a clot.

2.rain drop....drip. 4.syrup....sap. 6.champion....chump.

3.acorn....nut. 5.asp'rin....dope. (and so on: make up your own)

ALOUETTE

Remember that "alouette" is a bird and that "plumerai" means "to pluck out." So let action follow words: touch body part referred to: tete=face; bec=beak (mouth); nez=nose; cou=neck; pied=foot; dos=back.

SONGS - Trick Songs

VIVE L'AMOUR WITH HEY!

(Scout Songbook, 124)

Let ev'ry good fellow now join in my song,

Vive la compagne HEY!

Success to each other and pass it along,

Vive la compagne HEY!

Vive la, vive la, vive l'amour.... (etc.)

Vive la compagne HEY!

(very loud yell of "HEY!" - maybe jumping up - after word "compagne" in all verses)

HALF AND HALF

Divide groups into two sections. Sing familiar song (such as There's a Long, Long Trail) through once. Then announce that only group at which you point will sing - loudly, but good. Wind up by pointing to both groups to finish song in unison.

If printed on heavy stock, cut along solid lines to make file cards. If printed on paper, cut apart, paste on file cards to create your SCOUTCRAFT FILE.



CAMPFIRES—CLAPS, CHEERS—Claps for fun and coordination. Cheers for applause and fellowship spirit.

CLAPS

A-B-C-CLAPS

Famous Class A Clap - If some don't know it, start by counting loud while clapping:

"1-2-3-4 3-4 3-4 - 1-2-3-4 3-4 3-4 - 1-2-3-4 - 1-2-3-4 -1!"

Then simply clap:

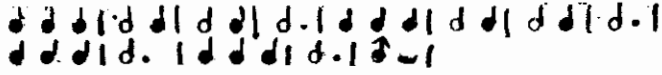

Repeat faster.

Class B Clap "is exactly the same as Class A - except you don't clap that last clap you clapped in Class A."

Class C Clap "is exactly the same as Class A and B - except you don't clap that last clap you clapped in Class A and which you didn't clap in Class B - and then you remember you didn't clap that last clap you clapped in Class A and which you didn't clap in Class B - and then you clap it."

CLAPS

HITCHHIKER'S CLAP

Teach this clap by counting loud while clapping:

1-2-3-4-5 - point thumb to right, hitchhiker style.

1-2-3-4-5 - point thumb to left

1-2-3-4-5 - point thumb upward

1-2-3-4-5 - point thumb downward

1-2-3-4-5 - point thumb to right, to left, upward, downward

(Do the clap slowly at first, say "Much too slow!" Then do it fast.)

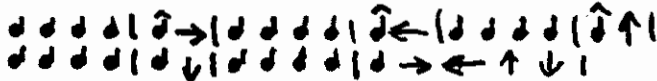

CLAPS

MOSQUITO CLAP

Each Scout follows an imaginary mosquito, pointing at it with an index finger, as it flies around, humming "Bzzzzz." Mosquito lands on Scout's left forearm: "Cluck" (make sound with tongue). Mosquito sucks blood: "Sluuuurppp." Scout smacks it with his right hand, "Smack!" and laughs loudly three times "Ha, ha, ha!"

RAIN CLAP

Start by tapping right thumb on palm of left hand to represent first few drops of rain. Then use two fingers, three fingers, four fingers, five, palm of hand - from soft clapping to very loud. Then in reverse order back to thumb on palm - as the rain passes.

CLAP

APPLAUSE CLAP

Leader divides group into two sections. Each section claps only when leader points to it. Start slowly, build up speed. Wind up by pointing to both sections.

HANDKERCHIEF CLAP

Leader throws handkerchief in the air, then catches it. All clap while it is in the air, then stop. (Leader may fool group by not actually throwing handkerchief.)

FREIGHT TRAIN CLAP

Clap simulates freight train starting off with great effort, gaining speed, passing by with great noise, disappearing into far distance, with a few whistles along the way. Vary by speeding up, slowing down, stopping (giving off steam), starting up again.

CHEERS for Applause and Spirit

INDIAN "HOW!" CHEER

For mild approval, leader leads in an emphatic "HOW!" For greater approval: "HOW! HOW!" For even greater: "HOW! HOW! HOW!" For greatest: "HOW! HOW! HOW! UG!"

BRAVO CHEER

"B-R-A-V-O - BRAVO! BRAVO! BRAVO!" (pronounced BROW)

AMERICA CHEER

"A-M-E-R-I-C-A! Scouting! Scouting! U-S-A! Rah!"

BROWNSEA CHEER

Leader: Who are we?

Chorus: "We're the boys who make no noise!

"Whooo-haaaah! Who-ha-haah! Who-ha-who-ha-who-ha-haah!

"Brownsea! Brownsea! Brownsea!" (or patrol name).

If printed on heavy stock, cut along solid lines to make file cards. If printed on paper, cut apart, paste on file cards to create your SCOUTCRAFTFILE.



CAMPFIRES—SKIT PLOTS—Outlines only for five simple skits. Add your own dialogue and stage "business."

Skit Plots

Whole Patrol

THE ECHO

Announcer: "We are at a resort hotel in the mountains. Manager is waiting for his guests." Guests arrive. 1st Guest: "I understand you have a good hotel." Manager: "Absolutely." 1st Guest: "With excellent food." "Absolutely." "And a fine view." "Absolutely." "But what do you have for entertainment?" Manager: "The most extraordinary echo in the world." 1st Guest: "Let me try. (Yells) HEY THERE!" Echo (hidden boy outside campfire circle): "Hey there." 2d Guest: "Now let me try," yells something, Echo answers. Other guests try in turn, with Echo answering. Last guest yells: "HOW ABOUT A DRINK?" Echo: "I'll be right down."

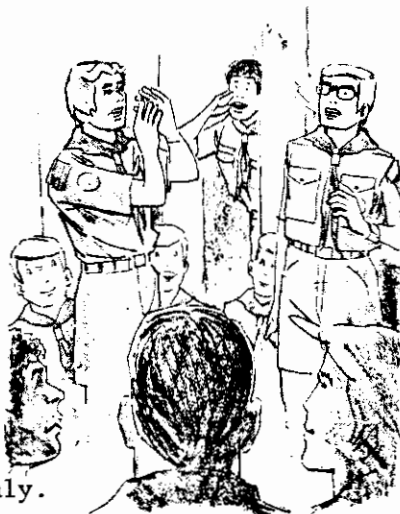

NOTE: This is "canned" plot only. Add your own dialogue and action.

Three Scouts

HAIR (Silent Show)

1st actor runs hand through his hair, makes great show of pulling out one "hair." Pulls out other imaginary "hairs." "Ties" them together two by two and places them on arm, like waiter carrying a napkin. Picks up "tied" "hairs" and rolls them between fingers to make "rope." Stretches "rope" to length of outstretched arms. Gives 2d actor one end to hold, stretches "rope" even further. 1st and 2d actors start swinging "rope" like skipping rope. 3d actor jumps in. Then 1st and 2d have a tug-of-war. 3d cuts "rope" with knife. 1st and 2d fall to the ground. Get up - walk out, 1st actor dragging rope after him (or "ties" "rope" to imaginary "dog" and lets "dog" lead him out).

Skit Plots

Three Scouts

Five Scouts or Whole Patrol

THE MAGNIFYING MACHINE

Two boys hold up blanket behind which are two boys with noise items (pots and pans) and "magnified" items as called for. Announcer: "Everything thrown into this machine will come out magnified." Throws in small stick - lots of noise - log comes flying over blanket. Then throws in (or has helpers throw in) other items: small ball = football - string = rope - nail = tent peg - etc. "Lady" enters with "baby" (doll) in arms. Leans over machine to see what is behind, loses "baby." Lots of noise - "lady" screams, noise stops. Out runs "magnified" "baby" (tallest Scout, stripped to underwear shorts, with towel around as diaper). Runs around campfire, yelling "Mama! finally sees mama, jumps up in "her" waiting arms, is carried out.

Skit Plots

Skit Plots



Skit Plots

Three Scouts or Whole Patrol

JUMBO, THE ELEPHANT

Announcer: "We are at the zoo, in front of the elephant cage." Points to sign that says "QUIET - SICK ELEPHANT." Two (or more) keepers enter, walk up and down, wringing their hands, moaning: "What are we going to do? Where is that doctor? Why doesn't he come - Jumbo may die. This suspense is awful," etc. Doctor enters. Keepers grab hold of him, pleadingly. "You must save him! You must save him!" Doctor: "I'll try, but Jumbo is very, very sick." Keepers moan, sob, behave desperately. Doctor: "I realize that you love the poor animal, but don't you think you are overdoing it?" Keepers (sobbing): "Love has nothing to do with it. If Jumbo dies, we're the ones who have to bury him."



NOTE: This is "canned" plot only. Add your own dialogue and action.

Skit Plots

Whole Patrol

UGH!

Six or eight "Indians," draped in blankets, with feather in hair, enter campfire circle in a single file. Walk silently twice around campfire, then seat themselves in a ring around the fire. Pause. 1st Indian (Chief): "Ugh!" 2d Indian: "Ugh!" 3d Indian: "Ugh!" And so on around the circle, until last Indian who says "Ugh-ugh!" Long silence, broken by 1st Indian: "If you can't stick to the subject, I'm getting out of here!" Rises, leaves campfire, followed by all the others. Effective if deadpan silence reigns throughout.





CAMPFIRES-DUEL CHALLENGES--I,
of Patrol, challenge of Patrol to (Also for
meetings)

Fitness Patrol Representatives Informal
INDIAN LEG WRESTLING

Equipment: Blanket, if desired.
Action: After a formal challenge, or elimination contests within the patrols, two patrol representatives lie down on a blanket side by side. Contestants' backs are flat on the ground, their legs in opposite directions. On signal "one," contestants raise their inside leg to a vertical position. On "two" they repeat this action, and on "three," each tries to lock leg with opponent and twist him over.
Scoring: Scout twisting opponent over two out of three times is winner. If both players should be twisted over simultaneously it is a tie. As in all dual contests, winner should be promptly challenged in a more or less formal manner by someone else until a troop champion is found, one Scout has been the winner three times in succession, a certain number of rounds have been played, or until a certain time has elapsed.

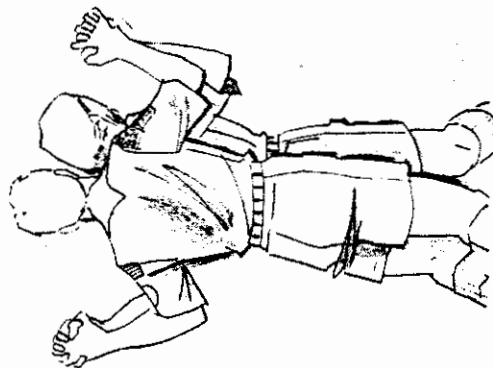

Fitness Patrol Representatives Informal

THE STRUGGLE

Equipment: None.
Action: Two selected patrol representatives face each other about a yard apart, stretch arms out sideways, lock fingers of both hands, and then lean toward each other till their chests touch, push chest to chest.
Scoring: Scout who drives the other back to the wall of the room or on to the goal line wins.

WRIST PUSHING

Equipment: None.
Action: Two Scouts face each other and put out their right hands as though they were going to shake hands. Instead, they press their wrists together. Each tries to turn the other around backward.
Scoring: The patrol having the most individual wins is declared the winner.
(Adapted from Baden-Powell's Scouting for Boys.)

Fitness Patrol Representatives Informal
INDIAN HAND WRESTLING

Equipment: None.
Action: One contestant places outside of his right foot against outside of the other's. Both brace themselves by placing left foot long step to rear. They grasp right hands and attempt to throw each other.
Scoring: First to succeed in making the other move a foot or lose his balance wins. Run contest for a best two-out-of-three.



SLAP JACK

Equipment: None.
Action: Contestant No. 1 places open hands, palm down, on upturned palms of contestant No. 2. No. 2 tries to pull one hand, or both, away quickly and slap opponent's hands on the back. When he fails, contestants change hand positions and No. 1 has his chance.
Scoring: First making given number of slaps is winner, or, most slaps in given time wins.

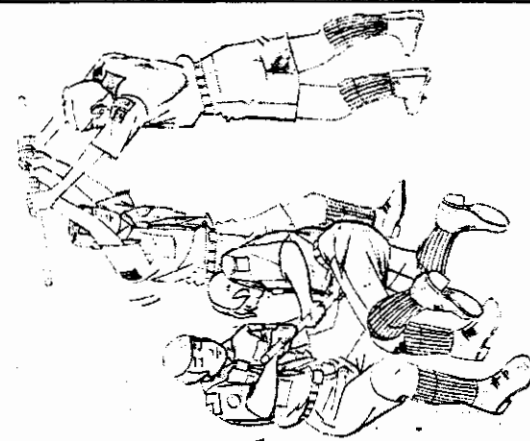

Fitness Patrol Representatives Informal
INDIAN ARM WRESTLING

Equipment: None.
Action: The two contestants face each other across a table. Each places his right elbow on the table in front of him and then grasps hand of his opponent. On the signal to start, each Scout presses to the left in an attempt to make his opponent's knuckles touch the table or to make his elbow leave the table. Scout is not permitted to use any other part of his body.
Scoring: The first to make his opponent's knuckles touch or elbow raise, scores a point. Two points out of three tries wins.
Variation-INDIAN THUMB WRESTLING: Scouts place fists on table, thumbs up and knuckles touching. Thumbs are raised and linked together. Scouts try to twist first so opponent's fist is raised off table. Two points out of three tries wins.



Fitness Patrol Representatives Informal

STICK FIGHT

Equipment: One Scout staff.
Action: Players face one another, with feet placed in wide, firm stance. Players grip stick firmly with both hands, each having his left hand on the inside of opponent's right hand. On signal, each tries to get stick to touch ground on his right side by pushing down with right hand and pulling up with left.
Scoring: Player succeeding in two out of three tries is the winner.
Variation-STICK TWIST: Players face one another and stand about a yard apart, gripping stick in similar manner as in Stick Fight, with the exception that contestants hold stick at eye level or higher. Object is to bring staff straight down without bending wrist or elbows or having stick twist in hands.



GAMES—NATURE—Five nature games for patrol teams, some of them also suitable for PL to stage for patrol.

Nature Patrol Teams Facing Lines

LEAF MATCHING

Equipment: Large table (or two tables) with seating capacity for two patrols.

Action: Part 1—Send patrols out to collect one leaf only from as many different trees as they can find. They have 5 minutes to do the job.

Part 2—One patrol is seated on one side of table, the other on the other side. Scout from one team holds up a leaf, identifies it, scores 10 points. First Scout on other team to hold up similar leaf scores 5 points for team. This second Scout then holds up a leaf, identifies it, scores as above. If a team identifies incorrectly the leaf it holds up, it scores nothing, but other team may score 10 points if it corrects mistake. If a team cannot match opponent's leaf, it misses its turn and opponent holds up another leaf for matching.

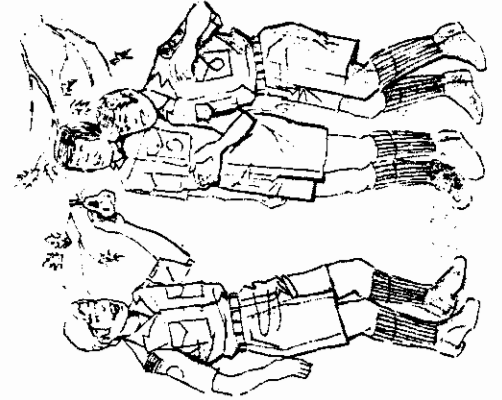

Nature Patrol Teams Informal

NATURE MEMORY HUNT

Equipment: On a large table, spread out a nature display consisting of approximately 20 items, such as:

- Acorn Cups
- Small rock
- Large burdock leaf
- Bundle of pine needles
- Broken bird egg shell
- Bird feather
- Local wild flower
- Fern frond
- Local wild berry or nut, etc.

Action: Part 1—Patrol has 5 minutes to observe the display, in silence, as Scouts try to memorize the items.

Part 2—After a huddle, Scouts scatter for 10 minutes to collect items corresponding to places their items next to the items in the original display.

Scoring: Patrols with most items in given time win. (If time permits, try to identify the items.)

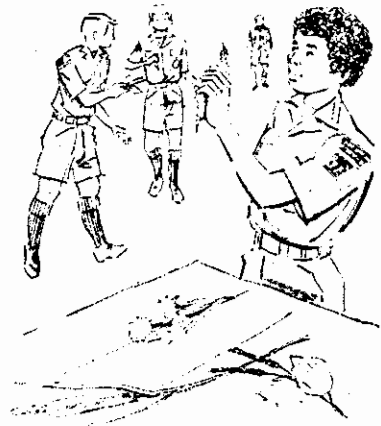

Nature Patrol Teams Informal

FREAK PLANT HUNT

Equipment: Pad and pencil for each patrol; items for "doctoring up" plants.

Action: In a given area, "doctor up" a number of different trees and plants—i.e., tying ash leaves on a tulip tree, having an orange "grow" on an oak tree, making daisy flowers "bloom" on a spicebush, etc. Explain area to be covered, give a definite time limit for returning, then send patrols out for ten minutes to find these freaks of nature.

Scoring: Patrol bringing back report of greatest number of nature oddities wins.

Variation: Have leaders lay a simple trail. Place freak plants and nature oddities along trail. Run game as a speed and observation test.

Scoring: First patrol returning wins 25 points. Patrol with longest list of freaks wins 50 points—or proportionate points according to things seen.

Nature Patrol Teams Informal

EDIBLE PLANTS WHO'S WHO?

Equipment: 20 (or more) edible plants in No. 10 tin, numbered from 1 to 20. Card at each plant gives name of plant and part that is edible, for instance "Cattail - pollen for flour - shoot for greens - root (rhizome) for starch." Pencil and paper for boys.

Action: Part 1—Patrol walks around cans, silently, as boys read descriptive cards and try to learn plants and plant parts.

Part 2—All the identifying cards are removed. The patrol again walks around cans. The Scouts try to identify and list all plants and edible parts. Patrol goes into huddle and makes list of plant names and edible parts.

Scoring: 5 points for each plant correctly identified.



Nature Patrol Teams Informal

NATURE SCAVENGER HUNT

Equipment: Sealed letter for each patrol.

Action: Each patrol is given a sealed letter containing the following instructions: "Greetings my friends! Your senior patrol leader has contracted a terrible disease. He is suffering from acute mogigraphia and will not get better unless he drinks a dose of my patent antrmogigraphia formula. For this I shall need the items from this list within an hour from the moment you read this: twelve pine needles, six inches of sasafra branch, fourteen dandelion seeds, bit of rabbit fluff, five dead flies. . . . Good luck and good hunting! (signed) Crambambuly, Witch Doctor." (List should contain about twelve to twenty items, fitting your locality and the season.)

Scoring: Patrol bringing in largest number of items within one hour wins.

If printed on heavy stock, cut along solid lines to make file cards. If printed on paper, cut apart, paste on file cards to create your SCOUTCRAFTFILE.



PROJECTS—NATURE—Five naturecraft items, for Scouts working individually or in patrol groups.

NATURECRAFTS—Leaves

SPATTER PRINTING

Nail a piece of wire screening to a wooden frame on each side. Place frame over leaf lying pinned to a piece of white paper. Take an old toothbrush or other stiff brush and paint color over the screen with the heaviest coating around the leaf. Lift leaf off when paint is dry.

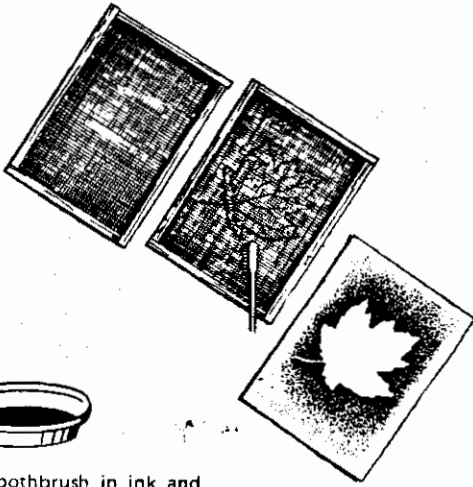

Primitive way: Dip toothbrush in ink and shake off surplus. Scrape knife across bristles to spatter paint on leaf.

NATURECRAFTS—Leaves

INK PRINTING

With a rubber roller, roll out a small dab of printer's ink on a glass plate. Ink underside of leaf, place leaf, inked side down, on white paper. Cover with a piece of newspaper and run roller over it. Don't let leaf shift position.

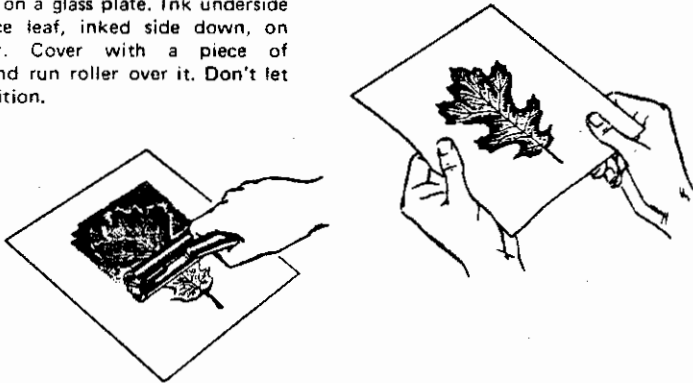

NATURECRAFTS—Leaves

SMOKE PRINTING

Coat piece of cardboard lightly with butter or petroleum jelly. Move back and forth

over lighted candle to pick up soot. Press leaf firmly against soot. Remove and press sooty side of leaf against clean paper.

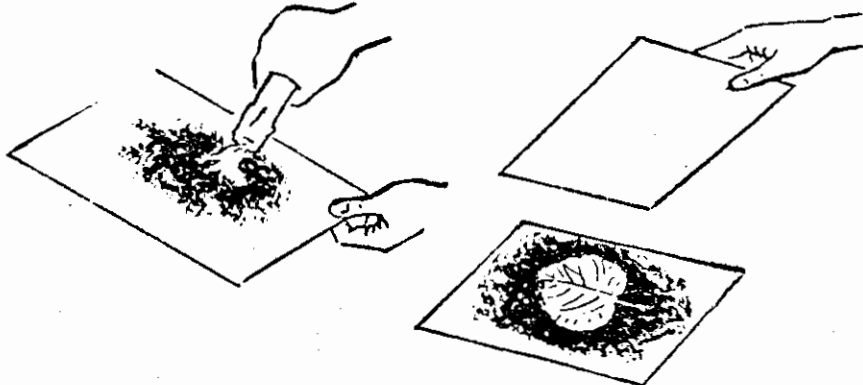

NATURECRAFTS—Track casts

TRACK CASTS

Place cardboard ring or ring cut from plastic bottle around track. Pour water into can. Add plaster to form small "island." Stir to make mixture like melted ice cream. Pour into track. Let stand until set. Mark with name, where found, and when.

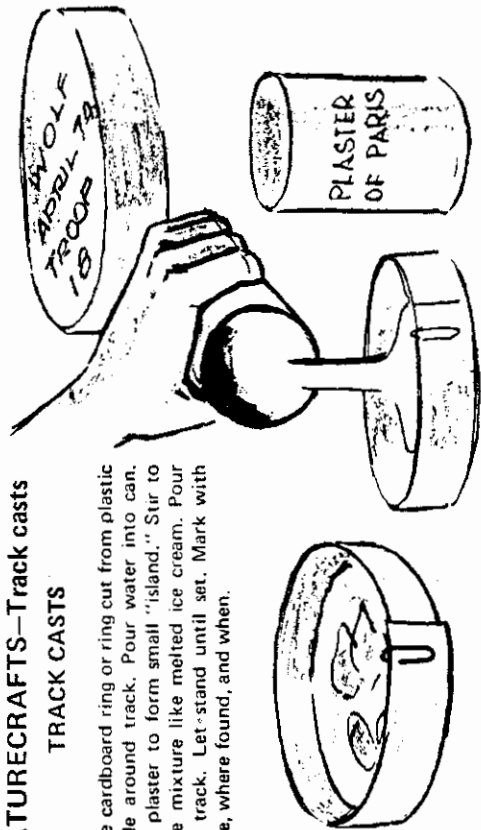

From time to time, pull fibers apart to tighten the twist. To add new fiber, twist the additional lengths into one strand, make cord past the splice, and then add new fiber to the other strand.

NATURECRAFTS—Twine, rope

TWINE AND ROPE MAKING

1. Twist fibers separately in a clockwise direction. 2. Hand-over-hand twist fibers together in a counterclockwise direction. 3.



If printed on heavy stock, cut along solid lines to make file cards. If printed on paper, cut apart, paste on file cards to create your SCOUTCRAFTFILE.



GAMES AND CONTESTS—COMPASS and MAP
III—Laying out the areas for compass and map games and contests.

COMPASS Layout for Compass Game

Course for Compass Game, No. 1133, can be set up by placing 20 numbered stakes in

ground (above) on a west-east line, No. 1 at west end. Or it can be a 100-foot string with numbered tags, 5 feet apart (below).

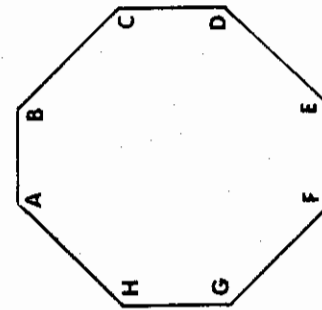
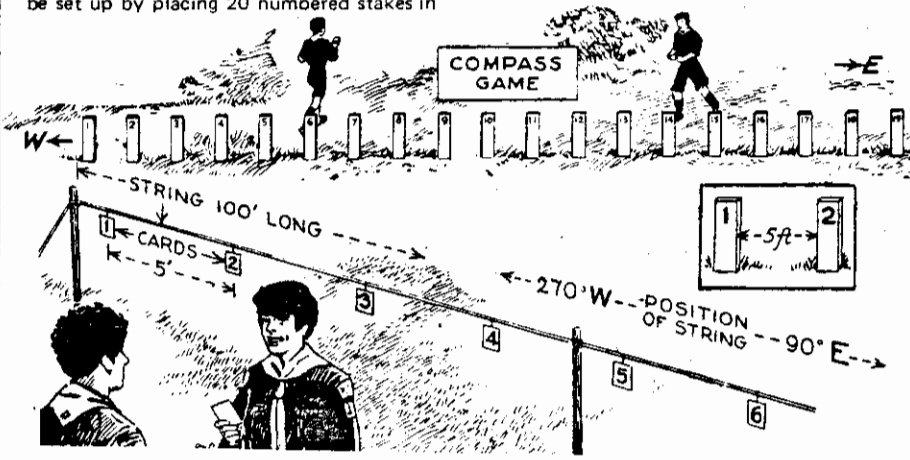

COMPASS Layout for Octagon Walk
(Determining directions)

Equipment: Place in the ground in a rather large area eight stakes, marked with letters A to H. For each Scout, Polaris compass, card with procedure, pencil.
Action: One Scout from each patrol takes position at each of the stakes. His card tells him to proceed to two other stakes and to return, taking bearings and measuring distances, such as "A to F, ft. F to D ft. D to A ft." (Numerous combinations are possible: B-F-C-B, G-C-A-G, C-A-F-C, F-B-C-F, and so on) Patrol with best answers wins.

COMPASS Layout for Compass Course

To lay the compass course "from flagpole to patrol site by or through model site," start at patrol site. Take back bearing (i.e., point direction arrow toward you) from patrol site to suitable landmark (tree, stone, etc.) in direction toward flagpole. Write down degrees. Measure distance. Take other back bearing to model camp, note degrees, measure distance. Once more, to flagpole.

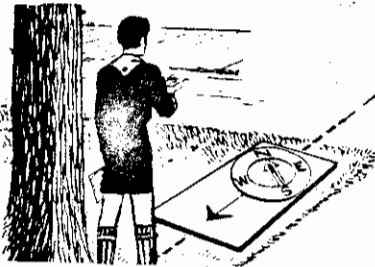
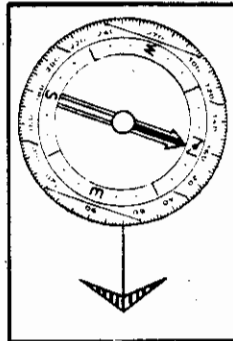

COMPASS - Markers for Orienteering Stations

Usual markers for orienteering stations consist of burlap banners, painted red and white, with code symbol in red. Tricky marker can be made from plastic gallon bottle. Make band of masking tape. Spray red. Include code.

Or make hollow prism of vinyl floor tiles painted red and white, as used in international Orienteering.

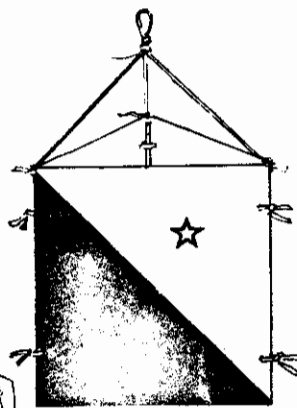
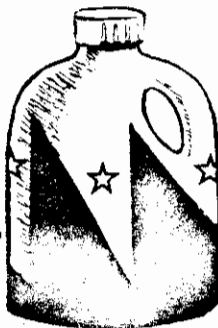

straight stick, with nails for exact pointing. Set up stakes with pointer pointing to landmark or feature in landscape. Indicate each landmark with description or a number.

Action: Run Direction Hunt as described on Gamefile card.

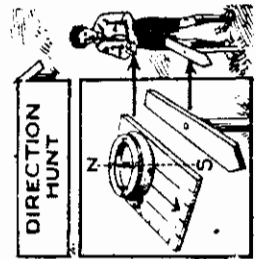

COMPASS Layout for Direction Hunt
(Determining directions)

Equipment: Secure eight tall stakes. Provide top of each of them with a pointer: either an arrowshaped piece of wood, or simply a

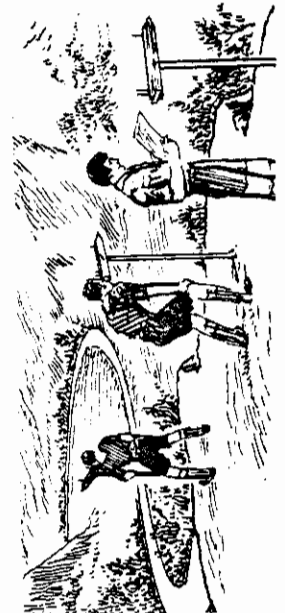



PROJECTS—COOKING—Main meal cooked in foil (meat, vegetables, bread, dessert). Possible overnight menu.

COOKING—Foil cookery

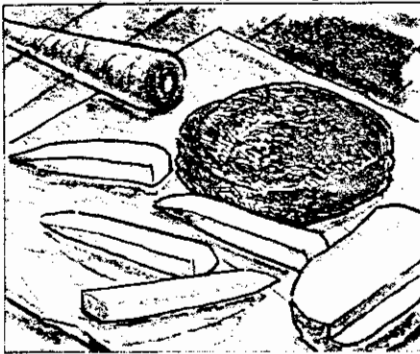

Cut up a potato into small pieces as for French fries. Cut up a carrot or two into "sticks." Pat 1/4-pound hamburger into a 3/4-inch thick cake. Place the ingredients side by side on a piece of foil, sprinkle with salt and pepper, wrap in the foil, and put the package into the coals. Cook 15

HAMBURGER A LA FOIL



minutes. For extra tastiness, smear mustard over the hamburger before cooking.

STEW A LA FOIL

Use chunks of stew meat instead of the hamburger. Add one cut onion, 1 tablespoon of water. Cook 25 minutes.

COOKING—Foil cookery

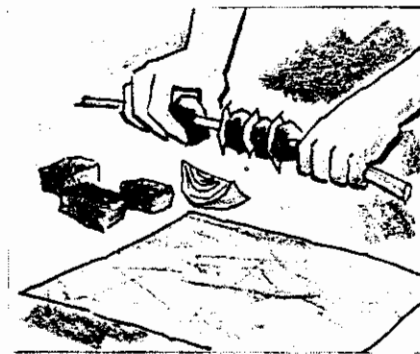

Make a skewer from a thin stick. Cut 1/4-pound lamb (or beef steak) into 1-inch cubes. Peel an onion, cut it lengthwise through the middle, and separate the leaves. String meat and onion alternately onto the

SHISH KEBAB OR KABOB

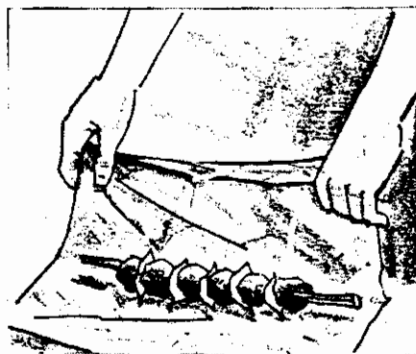

stick. If you have them, add pieces of tomato or green pepper, slivers of bacon, slices of cucumber. Wrap the kabob in aluminum foil and cook for about 14 minutes.

COOKING—Foil cookery

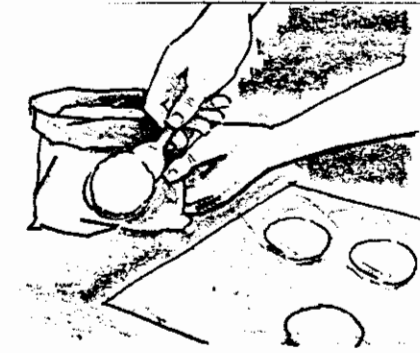

Use ready-mixed biscuit flour, or this recipe: Mix 1 cup flour, 1/4 teaspoon salt, 1 1/2 teaspoons baking powder, then cut 2 tablespoons lard into the flour mixture with a knife. With a stick make a crater in the

BISCUITS

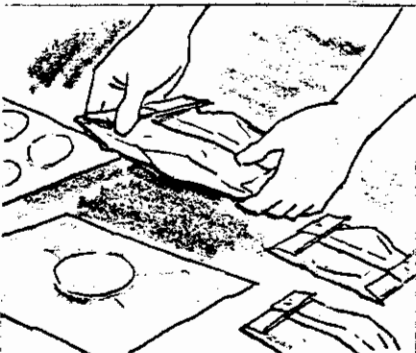

flour, pour in a small amount of water, stir until dough has formed. Pat into 1/2-inch-thick biscuits. Wrap loosely in aluminum foil, leaving room for dough to raise. Bake the biscuits about 10 minutes.

BAKED APPLE AND BAKED BANANA



banana, skin and all, in a piece of foil. Place wrapped-up fruit in the hot coals. Apple bakes in about 30 minutes, banana in 10. Serve in the foil.

COOKING—Foil cookery



Baked fruit makes excellent dessert. Cut a "lid" from top of apple, remove core, sprinkle in a teaspoon of sugar. Place in middle of piece of foil, bring corners over apple, then twist them together. Wrap

OUTPOST HIKE MEALS

- Utensils
 - 3 pots 1 pan
 - Chef's tool kit
 - Aluminum foil
- 4 plastic bags for sugar, biscuit mix, milk, apricots
- Preparation
 - For soup, biscuits, cocoa, and milk see packages
 - Stew: heat
 - Apricots: cook after supper

- Food From Stock
 - Jam or jelly
 - Sugar, salt, pepper
- From quartermaster
 - 3 packets pea soup
 - 3 1 1/2-pound cans stew
 - 1 box biscuit mix
 - 1 box fig cookies
 - 8 candy bars
 - 16 packets cocoa mix
 - 1 pound dried apricots
 - 8 individual cereals
 - 2 1-quart dry milk
 - 2 pounds bacon

COOKING

- Supper
- Soup
- Beef stew
- Biscuits
- Fig cookies
- Candy bars
- Cocoa
- Breakfast
- Stewed apricots
- Cereal and milk
- Bacon
- Biscuits
- Jam or jelly
- Cocoa

If printed on heavy stock, cut along solid lines to make file cards. If printed on paper, cut apart, paste on file cards to create your SCOUTCRAFTFILE.



GAMES AND CONTESTS-PATROL CHALLENGES—"Coup stick" events using logs. Also list of further suggestions.

Log-Rolling Patrol Teams Parallel File

LOG-ROLLING RELAY

Equipment: For each patrol, one log 3 feet long and 12 inches in diameter, eight stakes set in ground as shown in diagram.

Action: Patrols line up in relay formation facing the course. Two Scouts in each patrol roll the log up the course, between the sets of stakes, around the turning point, and back through the sets of stakes to the starting point where the next pair of Scouts takes over and repeats the process, and so on until eight Scouts have taken part.

Scoring: The first patrol to roll the log four times through the course is the winner.

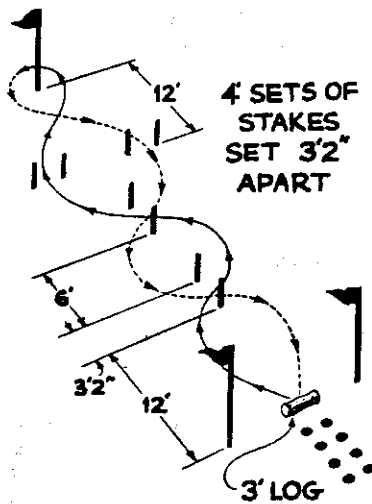

Various Formations

Patrol Teams

COUP EVENTS

Other possibilities (in addition to BrFr-I and BrFr-II)

Log-Sawing Events

BOW-SAW RELAY (BrMo-III-5) cutting 6-inch log disks with bow saw

CROSSCUT-SAW RELAY (BrMo-III-5) cutting 4-inch disks from 8- to 12-inch log

Scout Staff Events (If not used previously, or as repeat if popular)

ROMAN CHARIOT RACE (BrTh-II-4)

REACTOR TRANSPORTER (BrTh-II-3)

FLAGPOLE RAISING (BrTh-II-5)

Others

CHAIN GANG RACE (BrTh-I-5)

TENT-PEG DRIVING RELAY (BrMo-III-3)

TENT-PITCHING CONTEST (BrSu-I-4)

Patrol Challenges

Log-Raising Patrol Teams Parallel Line

LOG-RAISING RELAY

Equipment: For each patrol, a crossbar 10 feet high, a 3-foot log about 12 inches in diameter, and a 50-foot length of 1/2-inch rope.

Action: Patrols line up in relay style at starting line, 25 feet from crossbar. On signal the first Scout in each patrol coils rope and throws one end of it over the crossbar. He runs forward and ties one end of rope around the log with a timber hitch. He then hoists log off the ground by pulling on the free end of the rope. After log has cleared ground, he lets it drop, unties timber hitch, pulls rope from crossbar, and carries one end to starting line and touches off next Scout in his patrol who repeats the performance until all eight members have run the course. Scout failing to throw rope over crossbar after five attempts disqualifies his patrol.

Scoring: First patrol to finish is the winner.

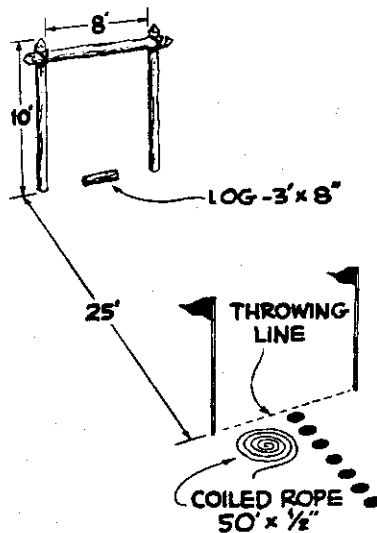

Log-Hauling Patrol Teams Parallel File

LOG-HAULING

Equipment: For each patrol one log, 5 to 6 feet long; one rope, 100 feet long. (Or use one log and one rope for all teams, taking time with stop watch.)

Action: Patrol ties timber hitch around log. Then each Scout ties a bowline-on-a-bight at intervals along rope (or overhand knots on double line, forming large loops). They place bights over shoulders as harness and drag log 50 feet across finish line.

Scoring: First patrol to cross with all knots tied correctly wins.



Axmanship Patrol Teams Parallel File

LOG-CHOPPING RELAY

Equipment: For each patrol one 3-foot log, 10 and 12 inches in diameter, held firmly in place with four stakes, one Explorer (three-quarter) ax. Object is to cut log in half with fewest number of strokes.

Action: At signal, Scout No. 1 runs up to log, takes six strokes, sticks ax in log, runs back, touches off No. 2 who runs up, takes six strokes, and so on. Continue until log is cut in two.

Scoring: Patrol cutting log in two with least strokes wins, NOT the patrol that does it fastest. Stress accuracy over speed.

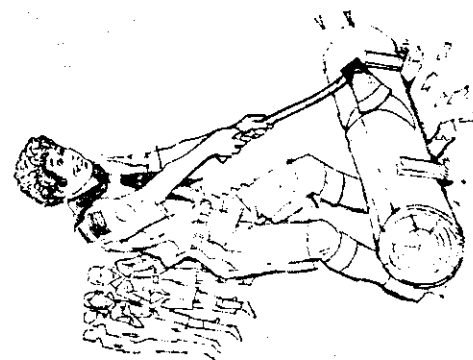



GAMES AND CONTESTS—PATROL CHALLENGES—A variety of "coup stick" events, using ropes for knots and lashings.

Knots Patrol Teams Informal

"HOT" ISOTOPE TRANSPORT

Equipment: Isotope "container" is a log, 6 to 8 inches in diameter, 10 inches long, set in the center of a 20-foot circle fenced with rope. Transporter is a 2 to 3-inch wide rubber band cut from an inner tube. To this band are tied eight 20-foot ropes. Object is to pick up isotope container from within circle (supposedly radioactive) and place it on the ground outside of the circle.

Action: Patrol lines up around circle. Each Scout grasps a rope. Under leadership of patrol leader, Scouts pull rope to stretch rubber band, then bring expanded band down over container, relax band to fit tightly around container, then lift and deposit container upright outside of the circle.

Scoring: Patrol doing job in shortest time wins. (Or have several containers. Patrol with the most out in a given time wins.)

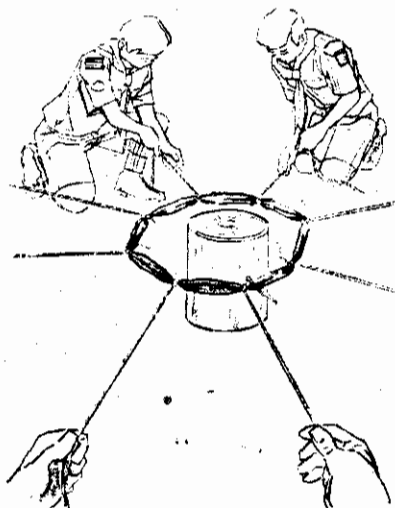

Knots Patrol Teams Informal

KICK BRIDGE

Equipment: Two 12-foot spars, two (or four) 20-foot guy-line ropes, one 6-foot rope, one 20-foot recovery line.

Action: Patrol ties guy lines to top of spar to be upright. It ties upright and horizontal together, with 6-foot rope, using clove hitches, so horizontal spar hangs loose. Recovery line is tied to free end of horizontal. Two (or four) Scouts man guy lines. First Scout to cross runs to upright, swings horizontal across "stream," gets off. Horizontal is swung back for next Scout, etc. Guy lines eventually are brought to opposite side.

Scoring: Patrol getting Scouts across in shortest time wins. Deduct for Scouts falling in "water."



Knots Patrol Teams Informal

REMOTE CLOVE HITCH TYING

Equipment: For each patrol a tree around which a 10-foot-radius area is staked out, not to be entered; one 50-foot rope.

Action: Two Scouts grasp rope at either end and are not permitted to let go. Object now is to tie clove hitch around tree without entering circle. Other Scouts are permitted to help with advice and by raising rope as needed. This is a fooler requiring lots of thinking!

Scoring: Patrol finishing first (or in shortest time) wins.

Variation—SQUARE KNOT TWO-MAN TYING

Equipment: For each patrol a 50-foot rope. Action: Two Scouts grasp rope ends and cannot let go. Object is to tie rope ends together with square knot. Other Scouts can help with advice.



Informal

Patrol Teams

Lashings

CATCH THE SNAPPER

Equipment: For each patrol four Scout staves, several lengths of cord, and a mousetrap.

Action: To form a "river" draw two parallel lines 15 feet apart. Patrols line up on "riverbank." On opposite bank from each patrol is a cocked mousetrap. Each patrol must lash their staves into a super-long fishpole with a fishline.

Scoring: First patrol to catch its snapper wins.

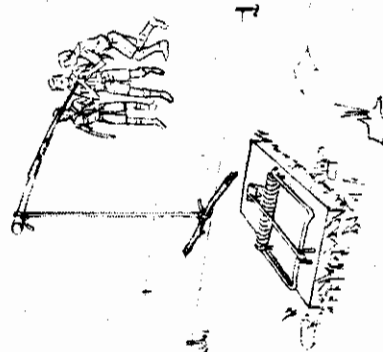

Informal

Half-Troop Teams

Fitness

TUG-O-WAR

Equipment: One rope at least 25 feet long.

Action: Two teams in single lines facing each other. Players take hold of rope, and at signal start pulling. Rope may not be tied around waist of players, nor can players hold onto posts, trees, or any stationary objects.

Scoring: First team pulling or dragging their opponents across a given line wins.

Variation—Teams are given pieces of rope 3-4 feet long. Players tie ropes together with sheet bends. Leader ties opposing team's ropes together and says "go." This method is not only a test of strength but also becomes a fine test of the patrol's knot-tying ability. If rope is unobtainable, a grape vine can be used. If team captain gets his players to "heave" together, team will have success even against superior strength.





GAMES—FIRST AID—Five games of patrol teams. At patrol meetings, use half-patrol teams.

First Aid Buddy Teams Informal

BUDDY BANDAGING

Equipment: Scout neckerchief or triangular bandage for each Scout.

Action: Patrols are seated in their patrol corners. A judge is assigned to each patrol. Each Scout selects a buddy from his own patrol. The name of a bandage is announced. On signal, one Scout from each team ties the named bandage on his buddy. The judge checks bandages as they are finished. As soon as a bandage is approved by the judge, it is removed, and the Scout on which the bandage was tied now ties the same bandage on his buddy. When the judge approves both bandages for each team in the patrol, the patrol has finished the first round. They use another type of bandage for the second round, etc.

Scoring: Score 1 point for the patrol finishing a round first. The patrol with the most points wins.



First Aid Patrol Teams Parallel File

ARM SLING RELAY

Equipment: Neckerchief or triangular bandage for each Scout.

Action: Patrols line up in relay formation with one Scout acting as a patient and standing in front of his patrol on the opposite side of the room. There is a judge for each patrol. On signal, the first man in each patrol runs to the patient and applies an arm sling. The judge observes. The instant he sees that the sling is correct, he shouts "off," and the Scout removes the sling and runs back to touch off the next member of his patrol. This continues until all in the patrol, except the patient, have tied a sling.

Scoring: First patrol through wins.

NOTE TO JUDGES: Slings must be correctly applied and adequate to serve the purpose.



First Aid Patrol Teams Parallel File

TWO-MAN CARRY RELAY

Equipment: Single turnaround post.

Action: Scouts line up in relay fashion facing a single turnaround post located 30 feet from the starting line. Scouts in the patrol shall be numbered from one to eight. On signal Scouts Nos. 1 and 2 will carry Scout No. 3 with a four-hand seat carry (for conscious patient) out and around the turnaround post and back to the starting line. Scout No. 3 will then join with No. 4 to carry No. 5 around the course. Then No. 5 will join No. 6 to carry No. 7 around the course, and finally No. 7 will join with No. 8 to carry No. 1 around the course. If at any time a victim touches the ground, the Scouts transporting this victim must stop, re-form their carry, and continue.

Scoring: The first patrol to make the full circuit with the four victims is the winner.

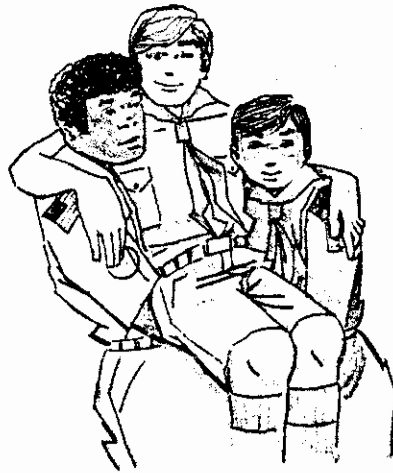

First Aid Patrol Teams Parallel File

STRETCHER RACE

(Not For Speed)

Equipment: Two staves, one strong blanket, and one inflated balloon for each patrol.

Action: Patrols line up in relay formation, two "victims" in front of each. On signal, two members of patrol run up with blanket and two staves, make stretcher, put one victim on it. Junior leader (or judge) places inflated balloon on victim when stretcher carriers are ready to lift stretcher. Victim is carried to starting line without balloon falling off (balloon is to assure care rather than speed). At starting line, victim is lifted off, and two other Scouts run up to make stretcher for transporting second victim.

Scoring: Patrol bringing both victims most carefully (without balloon falling off) to starting line, wins.

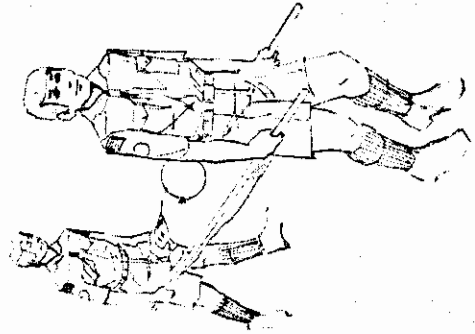

First Aid Patrol Teams Informal

REMEDIES

Equipment: A complete first aid kit for each patrol; splints and other first aid supplies as needed.

Action: The patrols sit in their patrol corners. A leader then takes from the kit those first aid items that have been used to treat a hypothetical first aid case. The patrol members carefully observe the items as they are presented. The leader then replaces all the items, and the patrol must decide what the injury has been.

Scoring: The first patrol to come up with the correct answer wins. If a patrol guesses wrong, it is disqualified.

VARIATION: YES AND NO REMEDIES. After the leader replaces the first aid items, he may answer the patrol's questions, but he may only answer "yes" or "no." Score as above or limit the number of questions.

